

TRION 20 DEVELOPMENT BOARD

CONTENTS

PAGE 01 - TABLE OF CONTENTS
PAGE 02 - BLOCK DIAGRAM
PAGE 03 - POWER SUPPLY & FTDI
PAGE 04 - CONTROL SIGNAL & SDRAM
PAGE 05 - POWER & CLOCK
PAGE 06 - GPIO & LVDS
PAGE 07 - GPIO HEADER

REVISION HISTORY

1.0	11/22/18	INITIAL CREATION
2.0	01/09/19	SECOND RELEASE
3.0	03/19/20	KCLEE ADDED NOTE FOR POWER-UP RECOMMENDATION

All material must comply with:

- 1. The requirements of the European Union RoHS 2 Directive 2017/2102 (Amendment to 2011/65/EU) with no exceptions unless authorized.**
- 2. The requirements of EC 1907/2006 and not contain any of the Substances of Very High Concern (SVHC) listed under the latest REACH requirements. (Amendments EU 2017/999, EU 2017/1510, EU 2018/35).**

No changes to Efinix bill of materials is allowed unless approved in writing by 易灵思 Product Engineering roup.

These changes will be maintained in the document revision history via ECN.

易灵思 1204 Qianhai Yidu Building, No. 99 Gangcheng Street, Nanshan District, Shenzhen, Guangdong, China					
Title: TABLE OF CONTENTS					
Size	Document Number: T20F256			Revision: 3.0	
Date	3/21/2020	Sheet	1	Text	7

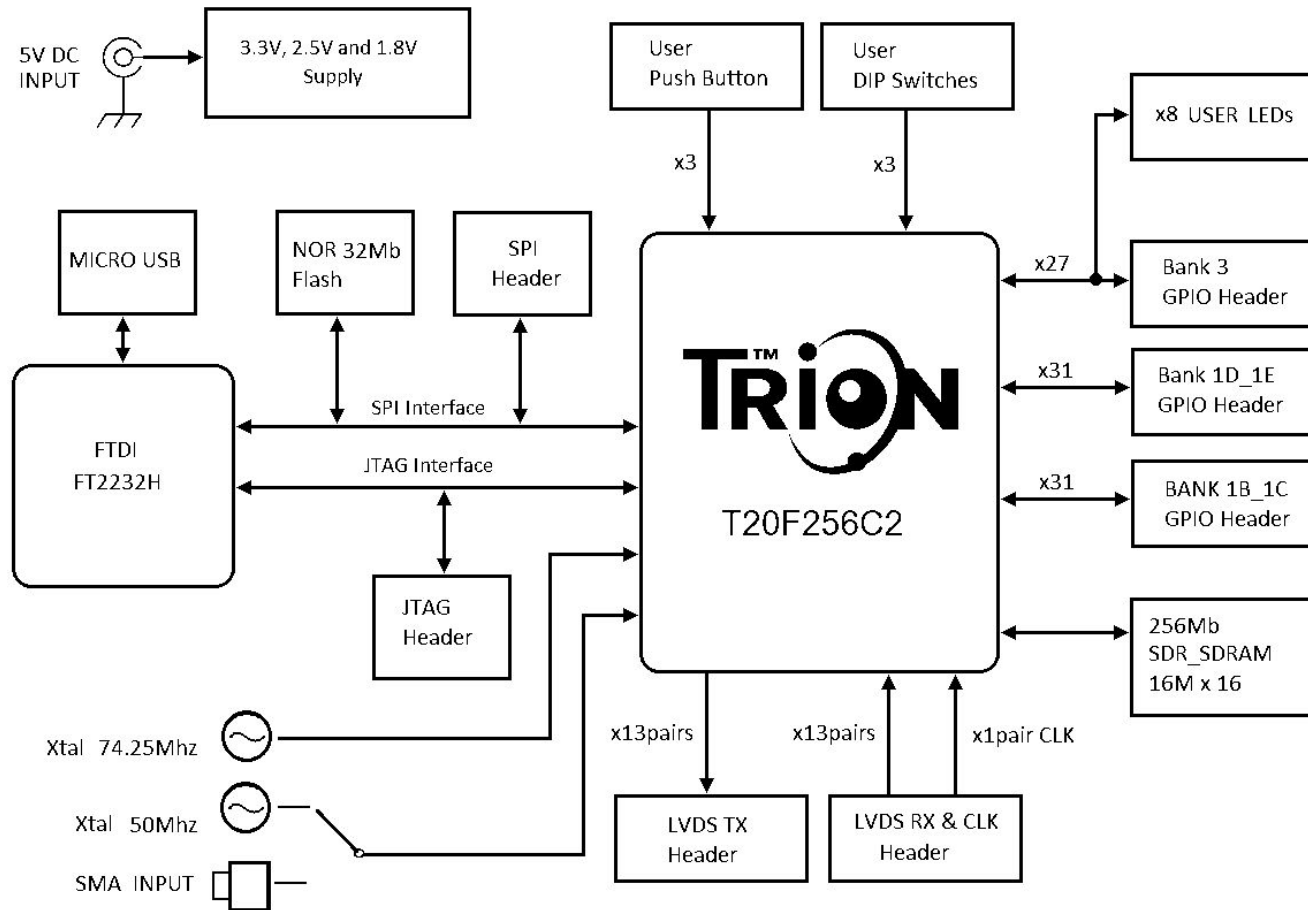

瑞灵芯 1204 Qianhai Yidu Building, No. 99 Gangcheng Street, Nanshan District, Shenzhen, Guangdong, China			
Title: BLOCK DIAGRAM			
Size	Document Number: T20F256	Revision: 3.0	
Date: 3/21/2020	Sheet: 2	Text	7

POWER

FTDI

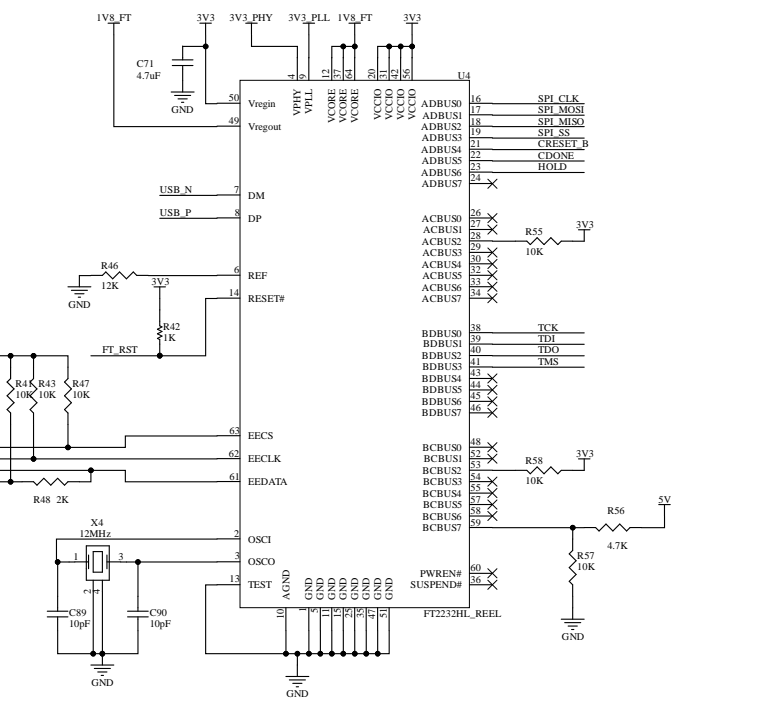
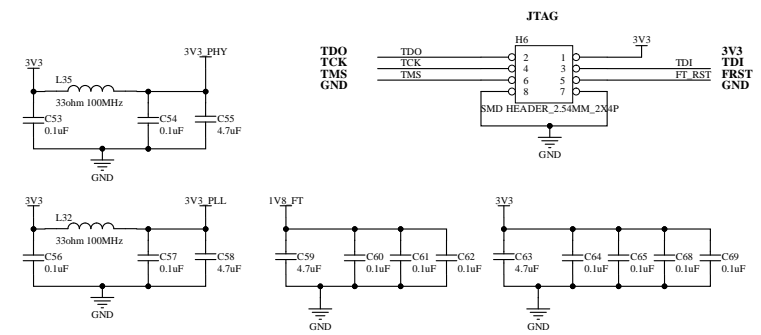
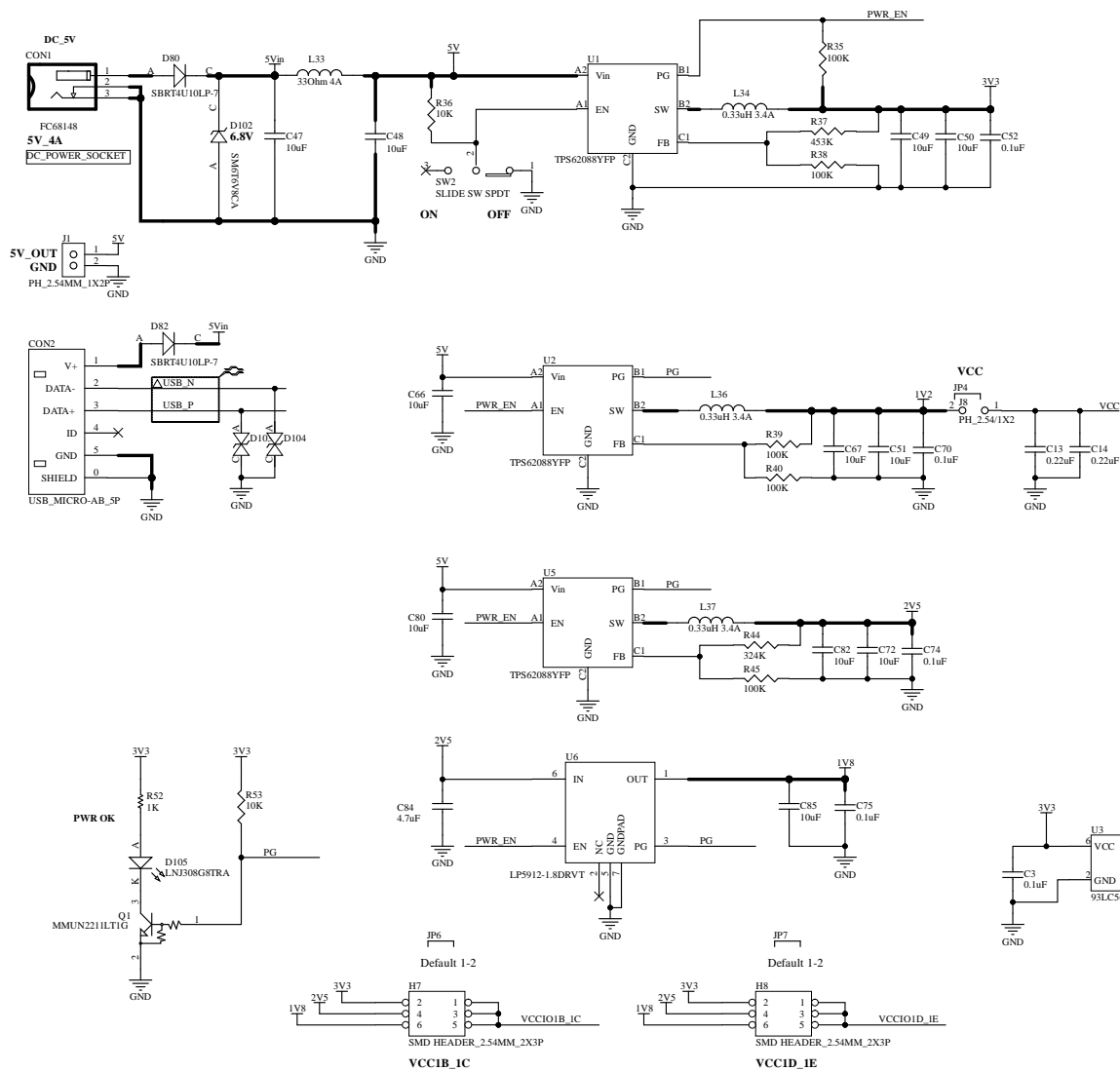

1-2 : 3V3
3-4 : 2V5
5-6 : 1V8

TRION T20 CONTROL SIGNALS

SDR_SDRAM

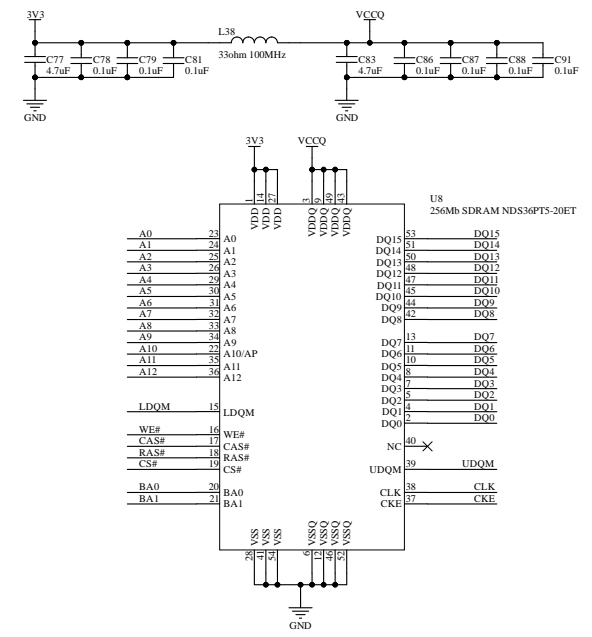
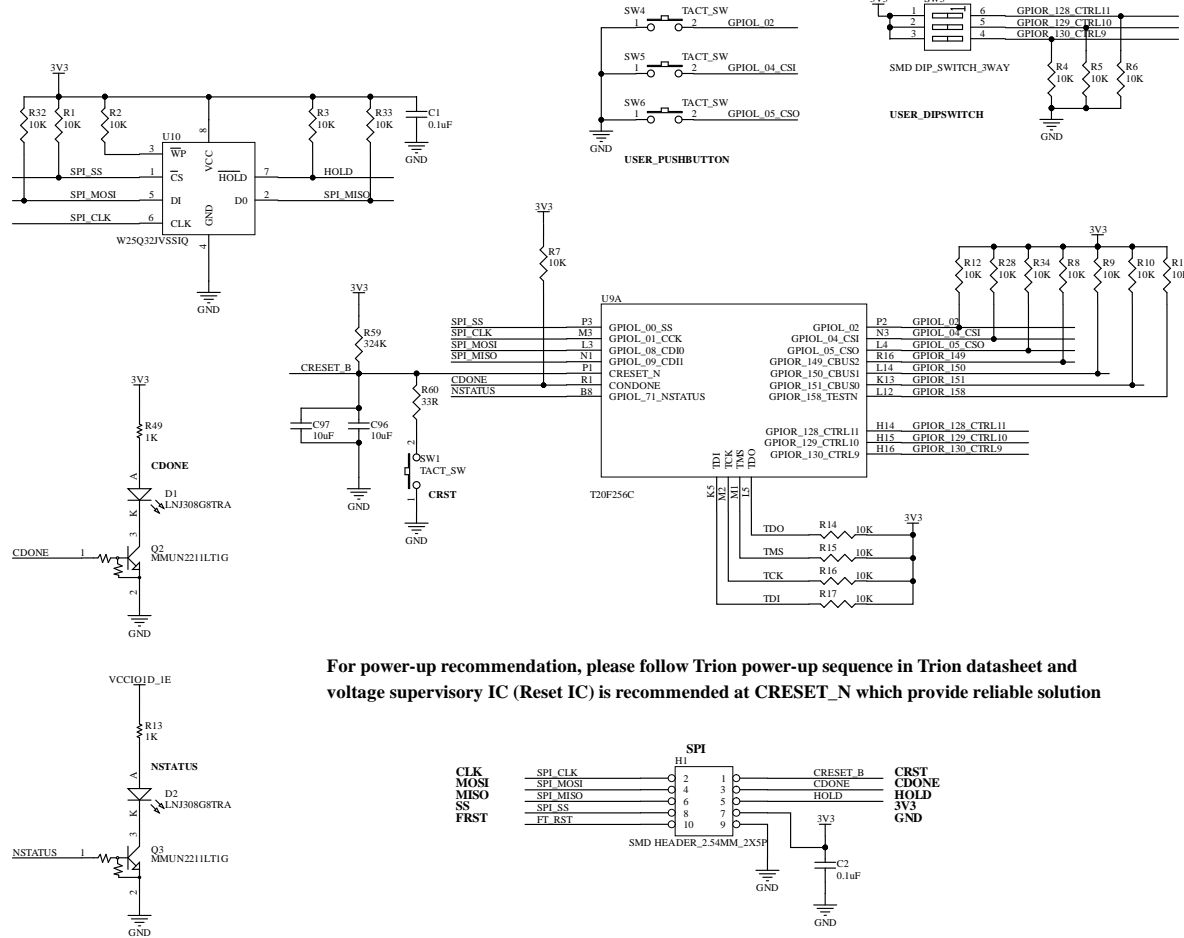

For power-up recommendation, please follow Trion power-up sequence in Trion datasheet and voltage supervisory IC (Reset IC) is recommended at CRESET_N which provide reliable solution

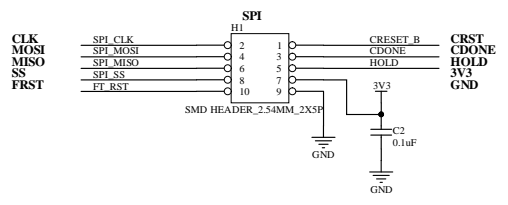

TRION T20 POWER AND CLOCK

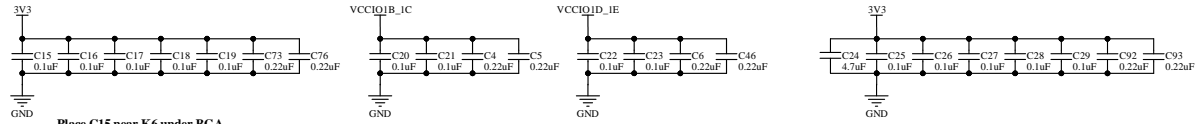

Place C15 near K6 under BGA
Place C16 and C17 near L10 and L11 under BGA
Place C18 and C19 near L6 and L7 under BGA
Place C73 and C76 near BGA

Place C20 and C21 near H6 and H7 under BGA
Place C4 and C5 near BGA

Place C22 and C23 near F6 and G6 under BGA
Place C6 and C46 near BGA

Place C25, C26, C27 near E10, F10, F11 under BGA
Place C28 and C29 near J10 and J11 under BGA
Place C24, C92 and C93 near BGA

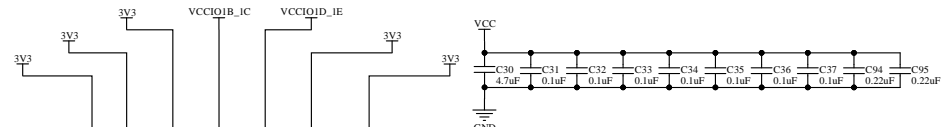

Place C31 and C32 near K9 under BGA
Place C33 and C34 near E9 under BGA
Place C35 and C94 near E9 under BGA
Place C36 and C95 near F8 under BGA
Place C30 and C37 near J6 and J7 under BGA

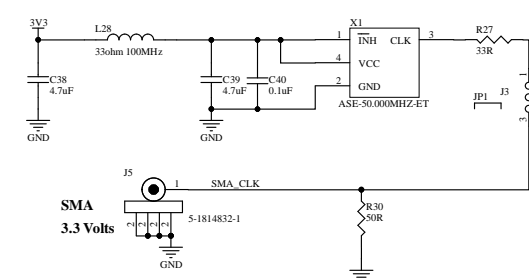

- GPIOL_24_CLK0 H3
- GPIOL_25_CLK1 H2
- GPIOL_26_CLK2 H4
- GPIOL_27_CLK3 G3
- GPIOL_28_CLK4 G5
- GPIOL_29_CLK5 G2
- GPIOL_30_CLK6 F1
- GPIOL_31_CLK7_CD16 G1

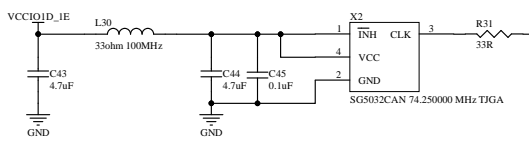

- GPIOL_74_PLL10 D9
- GPIOL_75_PLL11 E8
- GPIOR_76_PLL10 E9
- GPIOR_77_PLL11 D10

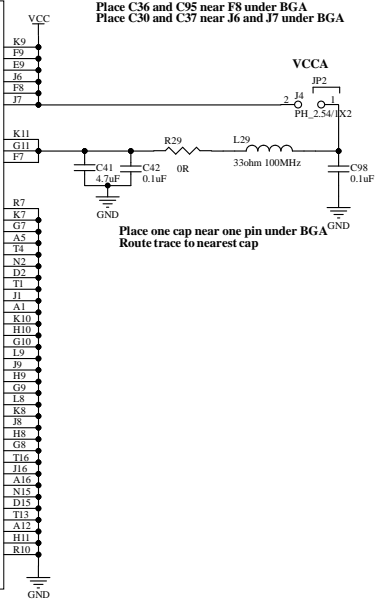
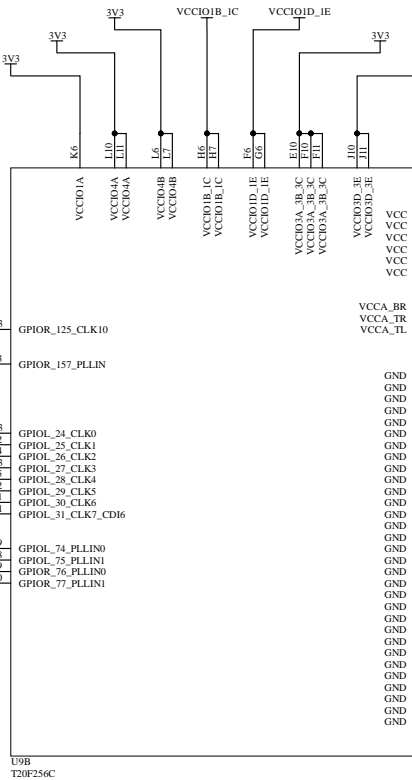

Place one cap near one pin under BGA
Route trace to nearest cap

GPIO & LVDS

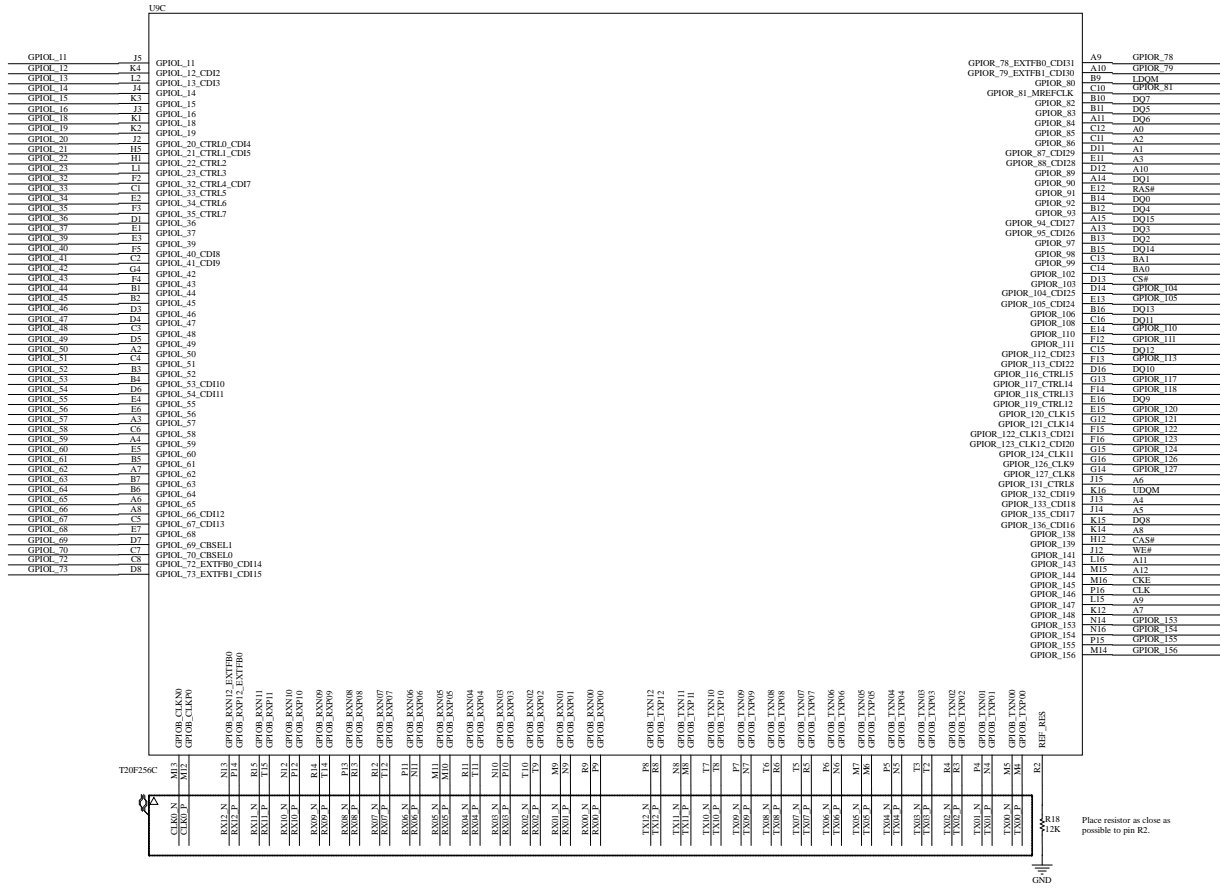

Place resistor as close as possible to pin R2.

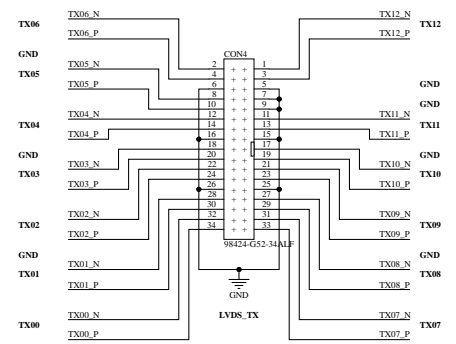
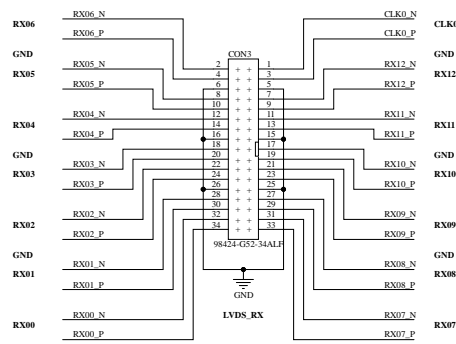

GPIO HEADER

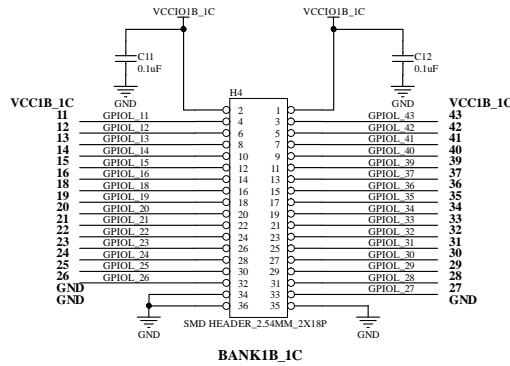
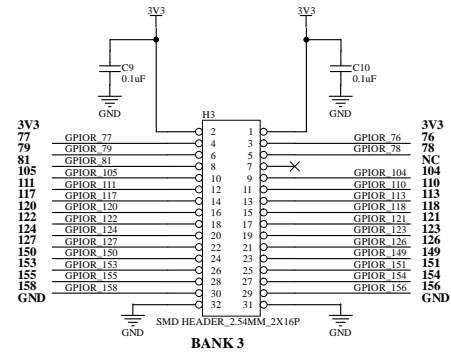
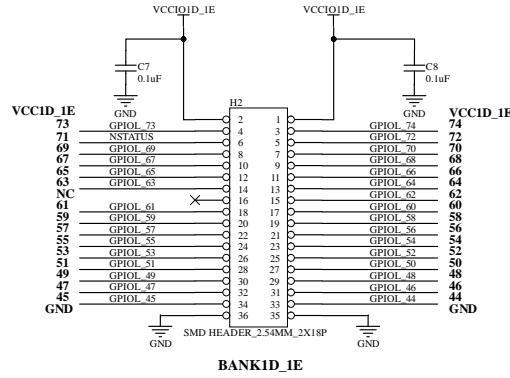
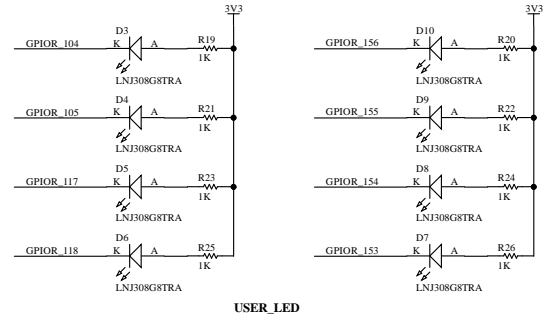
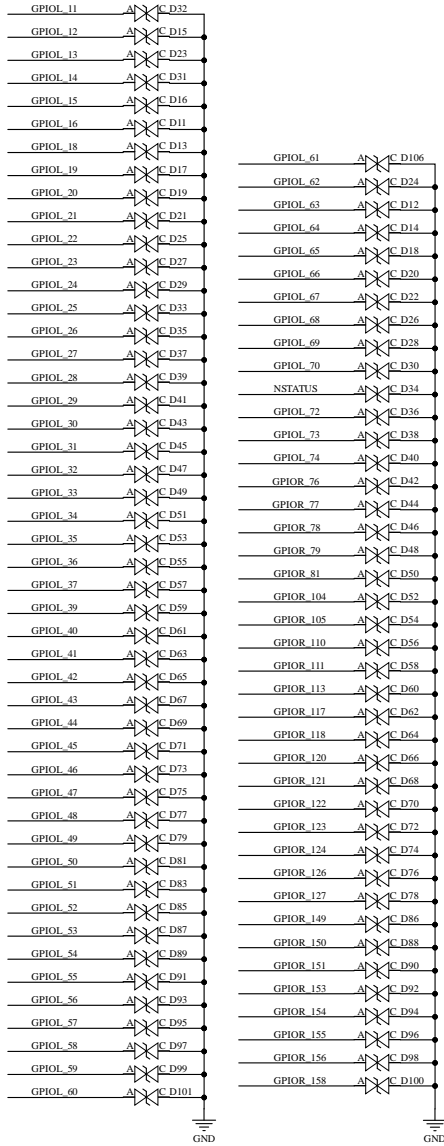

瑞灵思 1204 Qianhai Yidu Building, No. 99 Gangcheng Street, Nanshan District, Shenzhen, Guangdong, China			
Title: GPIO HEADER			
Size:	Document Number:	T20F256	Revision: 3.0
Date:	3/21/2020	Sheet: 7	Total: 7

Items	Part Types	Manufacturer Part Number	Manufacturer	Description	QTY	Reference
1	Shunt	S9337-ND	Sullins Connector Solutions	CONN JUMPER SHORTING .100"	5	JP1, JP2, JP4, JP6, JP7
2	Capacitor	C0201C104K9PACTU	Kemet	0.1uF 10V, 0201, MLCC	56	C1, C2, C3, C7, C8, C9, C10, C11, C12, C15, C16, C17, C18, C19, C20, C21, C22, C23, C25, C26, C27, C28, C29, C31, C32, C33, C34, C35, C36, C37, C40, C42, C45, C52, C53, C54, C56, C57, C60, C61, C62, C64, C65, C68, C69, C70, C74, C75, C78, C79, C81, C86, C87, C88, C91, C98
3	Capacitor	C0603X5R0J224M030BB	TDK	0.22uF 6.3V, 0201, MLCC	10	C4, C5, C6, C46, C73, C76, C92, C93, C94, C95
4	Capacitor	0603B224K100CT	Walsin	0.22uF 10V, 0603 MLCC	2	C13, C14
5	Inductor	MAKK2016HR33M	TaiYO YUDEN	SMT 0.33uH 20% 3.4A	3	L34, L36, L37
6	Resistor	RC0603FR-070RL	YAGEO	0 OHM, 0603	1	R29
7	Resistor	MC0603SAF1003T5E	Multicom	100K OHM, 0603	5	R35, R38, R39, R40, R45
8	Resistor	RC0603JR-0710KL	YAGEO	10K OHM, 0603	28	R1, R2, R3, R4, R5, R6, R7, R8, R9, R10, R11, R12, R14, R15, R16, R17, R28, R32, R33, R34, R36, R41, R43, R47, R53, R55, R57, R58
9	Capacitor	MCMT18N100F100CT	Multicom	10pF, ceramic	2	C89, C90
10	Capacitor	GRM188R60J106ME47J	Murata	10uF, MLCC	13	C47, C48, C49, C50, C51, C66, C67, C72, C80, C82, C85, C96, C97
11	Resistor	MCWR06X1202FTL	Multicom	12K OHM	2	R18, R46
12	Crystal	MCSJK-7U-12.00-12-10-80-B-10	Multicom	12MHz, SMD	1	X4
13	Resistor	MCWR06X1001FTL	Multicom	1k OHM 1/16W 1% 0603 SMD	12	R13, R19, R20, R21, R22, R23, R24, R25, R26, R42, R49, R52
14	SDRAM	NDS36PT5-20ET	Insignis Technology Corporation	256Mb SDRAM 16Mx16	1	U8
15	Resistor	MCWR06X2001FTL	Multicom	2K OHM	1	R48
16	Resistor	MCWR06X3243FTL	Multicom	324K OHM	2	R44, R59
17	Inductor	BLM15PX330SN1D	Murata	330hm 100MHz	6	L28, L29, L30, L32, L35, L38
18	Inductor	BLM21PG300SN1D	Murata	330hm SMT 2.2uH 20% 4A	1	L33
19	Resistor	MCWR06X33R0FTL	Multicom	33R	3	R27, R60, R31
20	Diode	CPDQC3V3C	COMchip Technology	3V3 Bidirectional TVS	91	D11, D12, D13, D14, D15, D16, D17, D18, D19, D20, D21, D22, D23, D24, D25, D26, D27, D28, D29, D30, D31, D32, D33, D34, D35, D36, D37, D38, D39, D40, D41, D42, D43, D44, D45, D46, D47, D48, D49, D50, D51, D52, D53, D54, D55, D56, D57, D58, D59, D60, D61, D62, D63, D64, D65, D66, D67, D68, D69, D70, D71, D72, D73, D74, D75, D76, D77, D78, D79, D81, D83, D85, D86, D87, D88, D89, D90, D91, D92, D93, D94, D95, D96, D97, D98, D99, D100, D101, D103, D104, D106
21	Resistor	MC0603SAF4701T5E	Multicom	4.7K OHM	1	R56
22	Ceramic	GRM155R60J475ME87D	Murata	4.7uF, MLCC	15	C24, C30, C38, C39, C41, C43, C44, C55, C58, C59, C63, C71, C77, C83, C84

23	Resistor	MCWR06X4533FTL	Multicom	453K OHM	1	R37
24	Resistor	FC0603E50R0BST1	VISHAY	50 OHM	1	R30
25	Crystal	ASE-50.000MHZ-ET	Abracon	Oscillator, 50MHz	1	X1
26	Connector	5-1814832-1	TE Connectivity	SMA	1	J5
27	Crystal	X1G004451009612	EPSON	Oscillator, 74.25 MHz, SMD, 5mm x 3.2mm, CMOS, 3.3 V	1	X2
28	IC	93LC56BT-I/O	Microchip	93LC56BT EEPROM	1	U3
29	Header	98424-G52-34ALF	Amphenol FCI	Male Header 2.0mm 34way	2	CON3, CON4
30	Connector	FC68148 DC10A	CLIFF Electronic	DC Power Socket PCB Mount	1	CON1
31	IC	FT2232HL-REEL	FTDI	FT2232HL_REEL	1	U4
32	Diode	LTST-C191KGKT	LITE-ON Inc	LED GREEN 573NM 1208 SMD	11	D1, D2, D3, D4, D5, D6, D7, D8, D9, D10, D105
33	IC	LP5912-1.8DRVR	Texas Instruments	IC REG LINEAR 1.8V 500MA 6SON	1	U6
34	Header	2211S-02G	Multicom	PH_2.54/1X2	3	J1, J4, J8
35	Header	2211SM-03G-B1-TB	Multicom	PH_SMD_2.54MM_1X3P	1	J3
36	Transistor	MMUN2211LT1G	ON Semi	10K at Base NPN	3	Q1, Q2, Q3
37	Rectifier Diode	SBRT4U10LP-7	Diode Incorporated	SBRT4U10LP-7	2	D80, D82
38	Slide Switch SPDT	OS102011MS2QN1	C & K Components	SLIDE SW SPDT	1	SW2
39	TVS	SM6T6V8CA	STMicroelectronics	SM6T6V8CA	1	D102
40	Dip Switch	MCEMR-03-T	Multicom	SMD DIP_SWITCH_3WAY	1	SW3
41	Header	61003221121	wurth electronics	SMD HEADER_2.54MM_2X16P	1	H3,
42	Header	61003621121	wurth electronics	SMD HEADER_2.54MM_2X18P	2	H2, H4
43	Header	2213SM-06G-TB	Multicom	SMD HEADER_2.54MM_2X3P	2	H7, H8
44	Header	2213SM-08G-TB	Multicom	SMD HEADER_2.54MM_2X4P	1	H6
45	IC	T20F256C	EFINIX	T20F256C	1	U9
46	Header	2213SM-10G-TB	Multicom	SMD HEADER_2.54MM_2X5P	1	H1
47	Tactile Switch	EVQPT9A15	Panasonic	Tactile Switch	4	SW1, SW4, SW5, SW6
48	IC	TPS62088FYPR	Texas Instruments	6-pin 3-A Step-Down Converter	3	U1, U2, U5
49	Connector	10104111-0001LF	Amphenol FCI	USB_MICRO-AB_5P	1	CON2
50	IC	W25Q32JVSSIQ	Winbond	3V 32Mb Serial Flash Dual, Quad SPI	1	U10



Disclaimers

易灵思 DOES NOT PROVIDES ANY WARRANTY OF ACCURACY, COMPLETENESS, MERCHANTABILITY OR NONINFRINGEMENT OF THIRD-PARTY RIGHTS ON THIS DOCUMENT. THE INFORMATION IN THIS DOCUMENT IS "AS IS". IN NO EVENT WILL 易灵思 BE LIABLE FOR ANY EXEMPLARY, SPECIAL, CONSEQUENTIAL, INDIRECT, OR INCIDENTAL DAMAGES, INCLUDING ANY LOSS OF DATA, LOST OF PROFITS, LOSS OF INFORMATION, LOSS OF LIFE OR BUSINESS INTERRUPTION, ARISING FROM YOUR USE OF THIS DOCUMENT.

易灵思 shall make changes to this document at any time without notification. 易灵思 assumes no obligation to correct any errors contained in this document or to advise any user of this document of any correction if such be made. 易灵思 advise its customers obtain the latest FPGA schematic before ordering so that no conflict of information correctness afterward.