

XYLONI DEVELOPMENT BOARD

CONTENTS

PAGE 01 - TABLE OF CONTENTS
PAGE 02 - GPIO BANKS
PAGE 03 - MICRO SD, LEDS, PUSHBUTTONS & GPIO PINS
PAGE 04 - FPGA POWER, CLOCK & MEMORY
PAGE 05 - USB & FTDI4232H

REVISION HISTORY

1.06 3/5/2018 Initial Creation

All material must comply with:

1. The requirements of the European Union RoHS 2 Directive 2017/2102 (Amendment to 2011/65/EU) with no exceptions unless authorized.
2. The requirements of EC 1907/2006 and not contain any of the Substances of Very High Concern (SVHC) listed under the latest REACH requirements. (Amendments EU 2017/999, EU 2017/1510, EU 2018/35).

No changes to 易灵思 bill of materials is allowed unless approved in writing by nix Product Engineering Group. These changes will be maintained in the document revision history via ECN.

1204 Qianhai Yidu Building, No. 99 Gangcheng Street,
Nanshan District, Shenzhen, Guangdong, China



Size	Document Number	Revision
A4	XYLONI-SCHE	V1.06
Date:	8/28/2020	Sheet 1 / 5

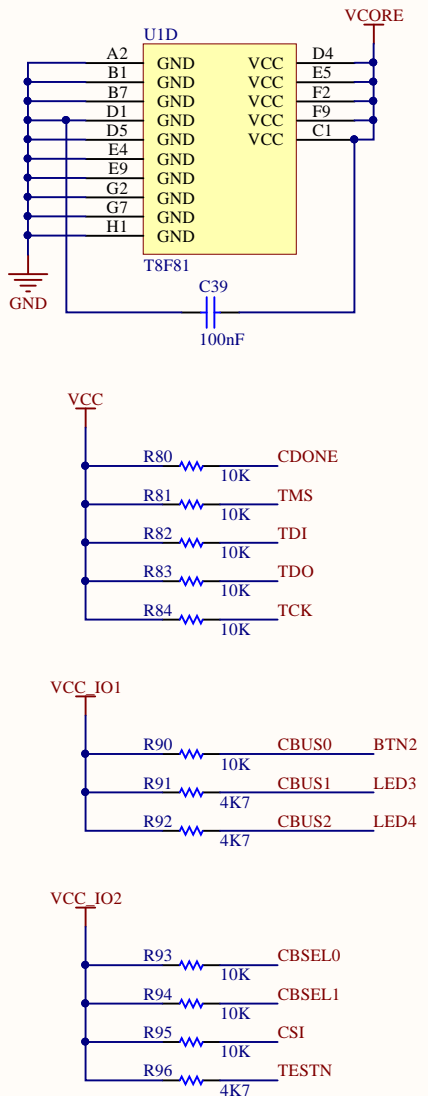
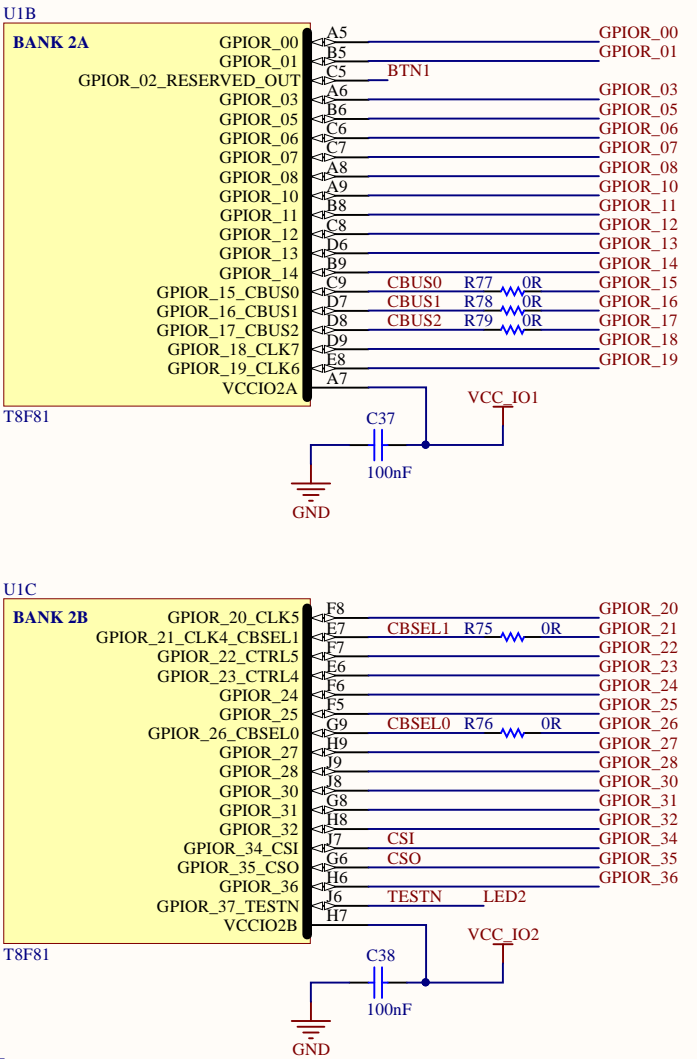
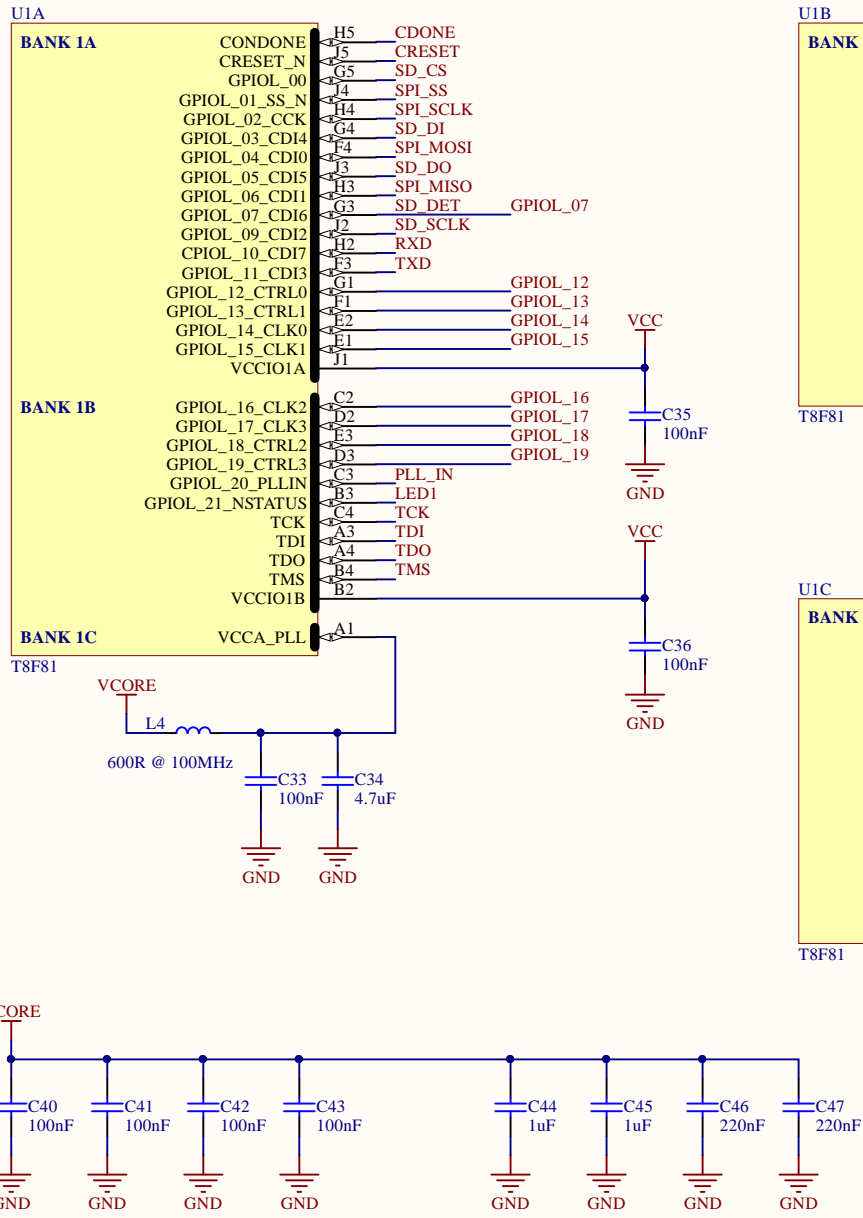

1204 Qianhai Yidu Building, No. 99 Gangcheng Street, Nanshan District, Shenzhen, Guangdong, China			
Size	Title	Revision	
A4	GPIO Banks	V1.06	
Date:	8/28/2020	Sheet	2 / 5

Micro SD Card Slot

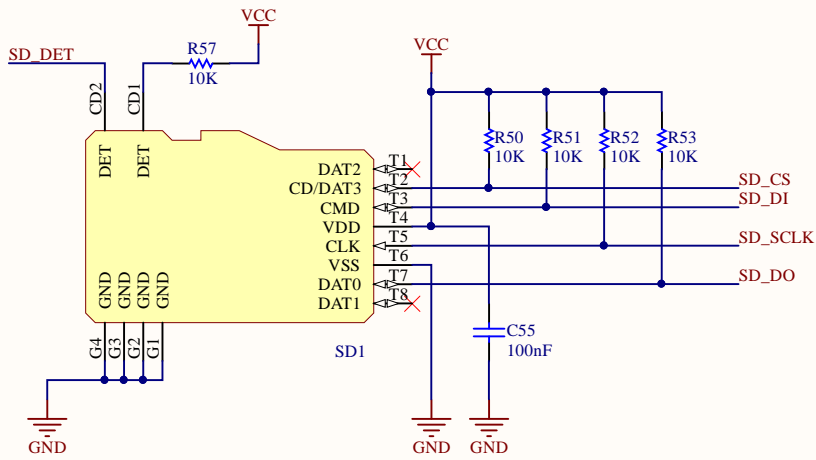

RESET

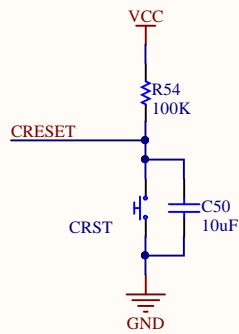

USER BUTTON

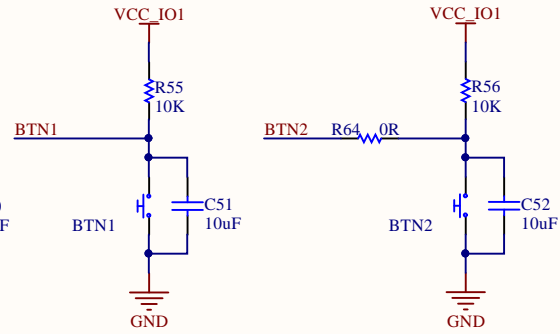

GPIOs

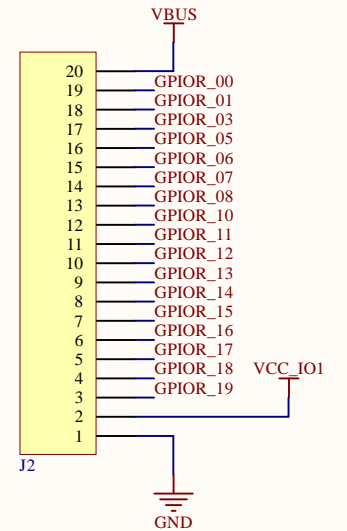
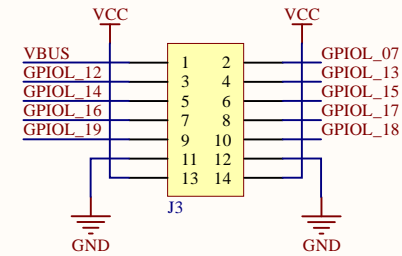
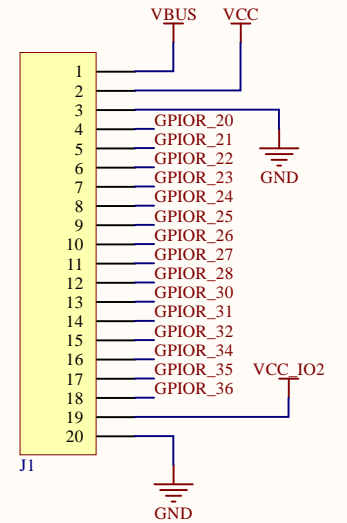

LED + LED Driver

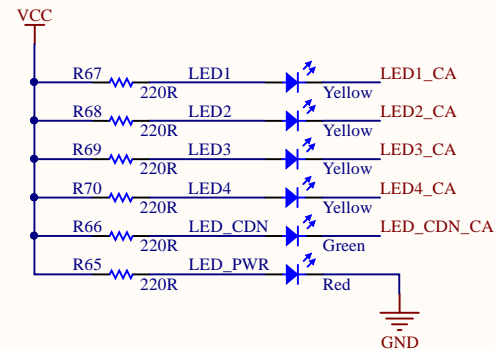
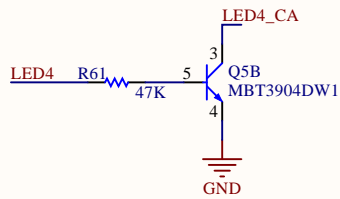
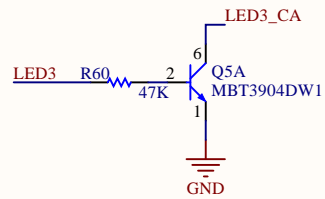
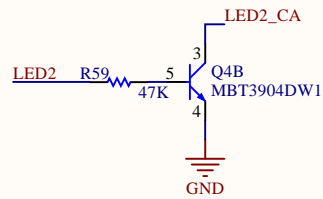
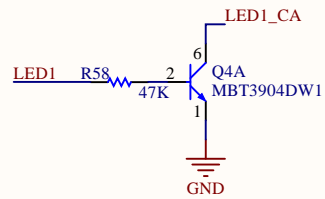
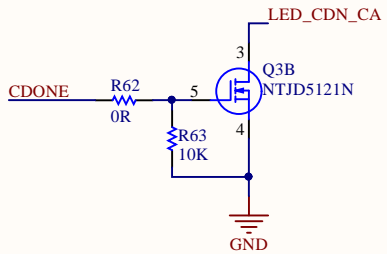

Test Points

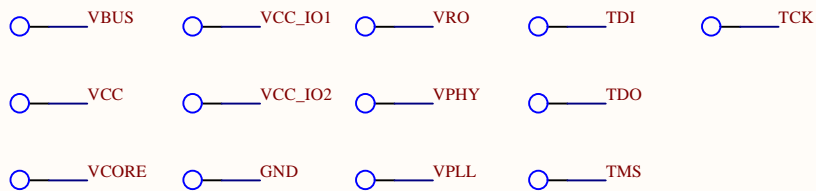

1204 Qianhai Yidu Building, No. 99 Gangcheng Street, Nanshan District, Shenzhen, Guangdong, China

Size	Title	Revision
A4	Micro SD, LEDs, Pushbuttons & GPIO Pins	V1.06
Date:	8/28/2020	Sheet 3 / 5

VCCIO1 Select (1.8V/2.5V/3.3V)

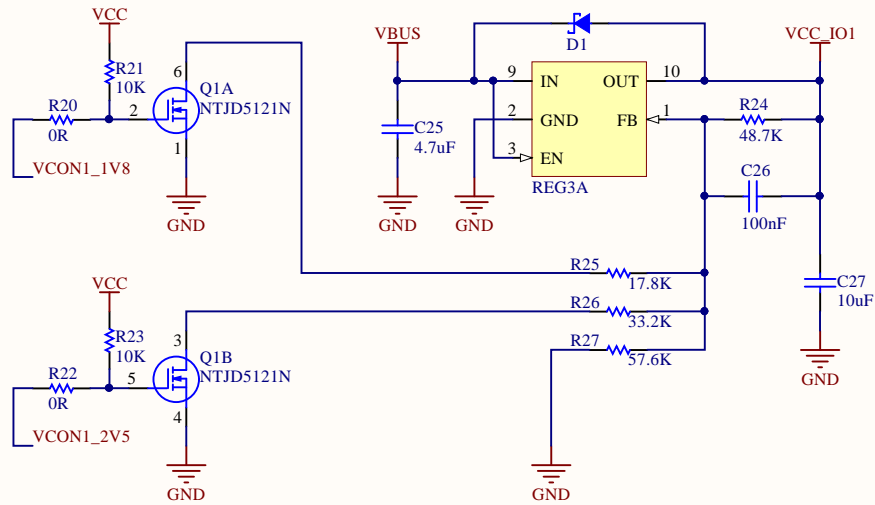

8M Serial NOR Flash

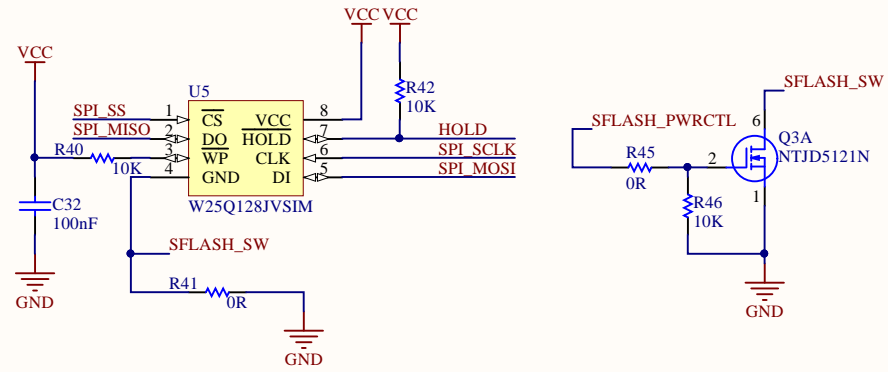

Oscillator (PLL)

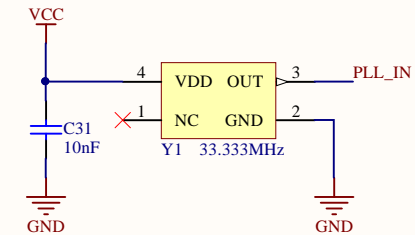

VCCIO2 Select (1.8V/2.5V/3.3V)

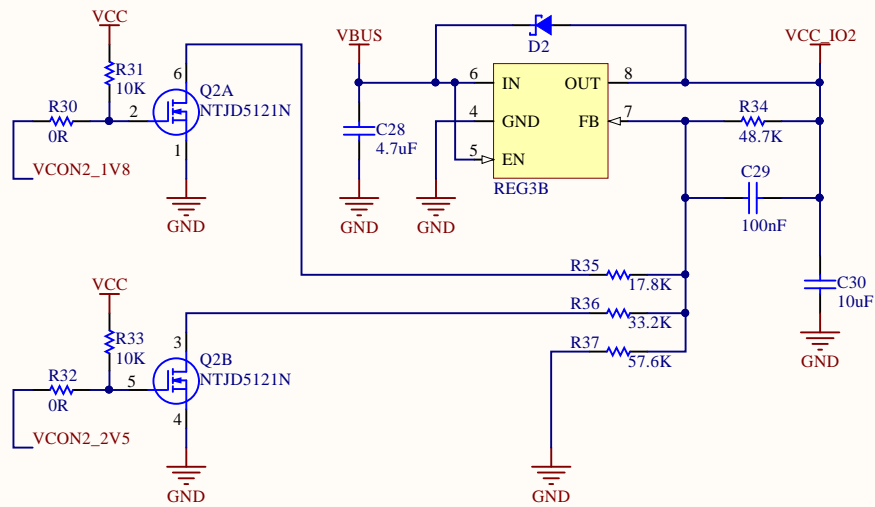

VCORE (1.2V)

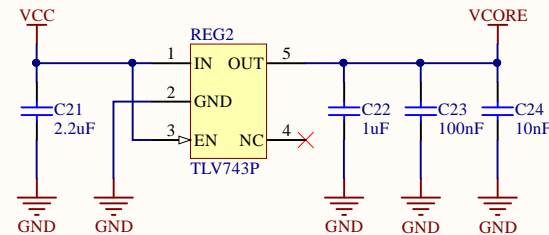

VCC (3.3V)

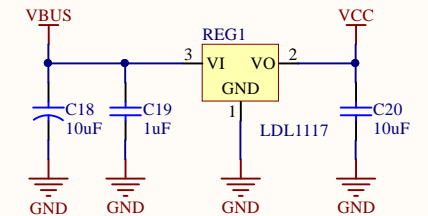

1204 Qianhai Yidu Building, No. 99 Gangcheng Street, Nanshan District, Shenzhen, Guangdong, China			
Size A4	Title FPGA Power, Clock & Memory	Revision V1.06	
Date: 8/28/2020	Sheet 4 / 5		

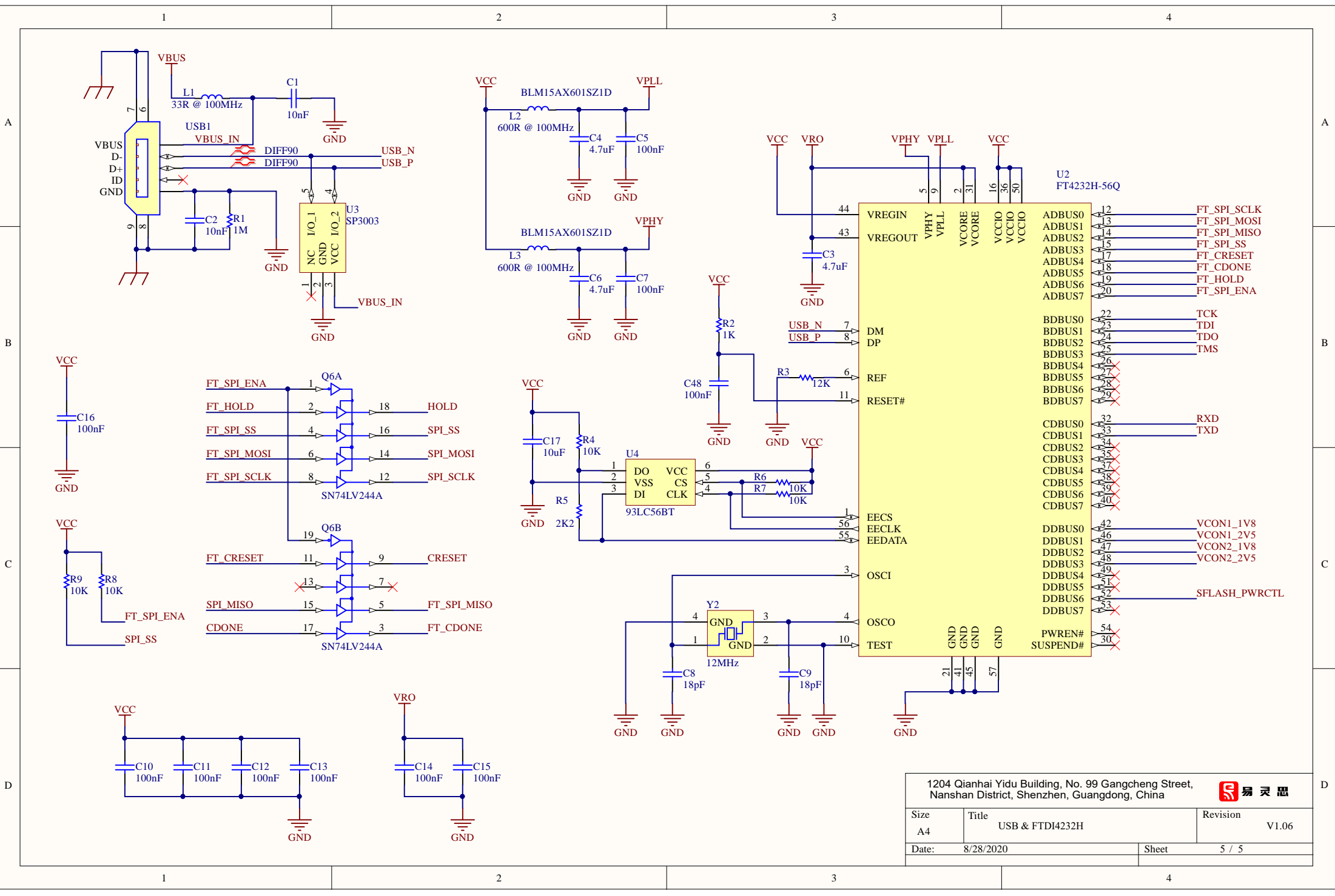

1204 Qianhai Yidu Building, No. 99 Gangcheng Street, Nanshan District, Shenzhen, Guangdong, China			
Size A4	Title USB & FTDI4232H	Revision V1.06	
Date: 8/28/2020	Sheet 5 / 5		



No	Comment	Description	Value	Footprint	Designator	Manufacturer	Manufacturing Part Number	Qty
1	SWITCH_SPST_PUSHON	Single Pole Single Throw Push-ON Switch		PTS820 J20	BTN1, BTN2, CRST	C&K	PTS820J20MSMTR	3
2	CAPACITOR	Capacitor	10nF	CAPC0402M	C1, C2, C24, C31	Murata Electronics	GCM155R71H103KA5J	4
3	CAPACITOR	Capacitor	4.7uF	CAPC0402M	C3, C4, C6, C25, C28, C34	Murata Electronics	GRM155R60J475ME7J	6
4	CAPACITOR	Capacitor	100nF	CAPC0402M	C5, C7, C10, C11, C12, C13, C14, C15, C16, C23, C26, C29, C32, C48, C55	Taiyo Yuden	EMK105B7104KV-F	15
5	CAPACITOR	Capacitor	18pF	CAPC0402M	C8, C9	Murata Electronics	GCM155C1H180JA6D	2
6	CAPACITOR	Capacitor	10uF	CAPC0402M	C17, C20, C27, C30, C50, C51, C52	Murata Electronics	GRM155C80J106ME1J	7
7	CAPACITOR	Polarized Capacitor	10uF	TANCAP-A	C18	Vishay	293D106X96R3A2TE3	1
8	CAPACITOR	Capacitor	1uF	CAPC0402M	C19, C22	Murata Electronics	GCM155C71A105KE8D	2
9	CAPACITOR	Capacitor	2.2uF	CAPC0402M	C21	Taiyo Yuden	LMK105BJ225KV-F	1
10	CAPACITOR	Capacitor	100nF	CAPC0201M	C33, C35, C36, C37, C38, C39, C40, C41, C42, C43	Murata Electronics	GRM033C71A104KE14D	10
11	CAPACITOR	Capacitor	1uF	CAPC0201M	C44, C45	Yageo	CC0201MRX5R4BB105	2
12	CAPACITOR	Capacitor	220nF	CAPC0201M	C46, C47	Murata Electronics	GRM033R61E224KE01D	2
13	Schottky Diode	Schottky Diode		SOD-323	D1, D2	Nexperia	BAT54J,115	2
14	TEST_POINT	Test Point		TP-SMD	GND, TCK, TDI, TDO, TMS, VBUS, VCC, VCC_IO1, VCC_IO2, VCORE, VPHY, VPLL, VRO			13
15	Header	Pin Header 1 Row 20 Pin		PHM-1R20P-2M54	J1, J2	Würth Elektronik	61302011121	2
16	Header	Pin Header 2 Row 7 Pin		PHM-2R7P-2M54	J3	Würth Elektronik	613012243121	1
17	FERRITE_BEADS	Ferrite Beads	33R @ 100MHz	RESC0603M	L1	Taiyo Yuden	BK1608HS330-T	1
18	FERRITE_BEADS	Ferrite Beads	600R @ 100MHz	RESC0402M	L2, L3	Murata Electronics	BLM15AX601S21D	2
19	FERRITE_BEADS	Ferrite Beads	600R @ 100MHz	RESC0603M	L4	Taiyo Yuden	BK1608HS601-T	1
20	LED	Light Emitter Diode	Yellow	LED0603	LED1, LED2, LED3, LED4	Lite-On	LTST-C191KSKT	4
21	LED	Light Emitter Diode	Green	LED0603	LED_CDN	Lite-On	LTST-C191KGKT	1
22	LED	Light Emitter Diode	Red	LED0603	LED_PWR	Lite-On	LTST-C191KRKT	1
23	NTJD5121N	MOSFET – Power, Dual,N-Channel With ESDProtection, SC-8860 V, 295 mA	NTJD5121N	SOT-363	Q1, Q2, Q3	ON Semiconductor	NTJD5121N	3
24	MBT3904DW1	Dual General Purpose Transistors, SC-88, hFE 100-30040 V, 200 mA	MBT3904DW1	SOT-363	Q4, Q5	ON Semiconductor	MBT3904DW1	2
25	SN74LV244A	Octal Buffers and Drivers With 3-State Outputs		QFN-20-RGY	Q6	Texas Instruments	SN74LV244ARGYR	1
26	RESISTOR	Resistor	1M	RESC0402M	R1	Yageo	RC0402FR-071ML	1
27	RESISTOR	Resistor	1K	RESC0402M	R2	Yageo	RC0402FR-071KL	1
28	RESISTOR	Resistor	12K	RESC0402M	R3	Yageo	RC0402FR-0712KL	1
29	RESISTOR	Resistor	10K	RESC0402M	R4, R6, R7, R8, R9, R21, R23, R31, R33, R40, R42, R46, R50, R51, R52, R53, R55, R56, R57, R63, R80, R81, R82, R83, R84, R90, R93, R94, R95	Yageo	RC0402FR-0710KL	29
30	RESISTOR	Resistor	2K2	RESC0402M	R5	Yageo	RC0402FR-072K2L	1



31	RESISTOR	Resistor	0R	RESC0402M	R20, R22, R30, R32, R41, R45, R62, R64, R75, R76, R77, R78, R79	Yageo	RC0402FR-070RL	13
32	RESISTOR	Resistor	48.7K	RESC0402M	R24, R34	Yageo	RC0402FR-0748K7L	2
33	RESISTOR	Resistor	17.8K	RESC0402M	R25, R35	Yageo	RC0402FR-0717K8L	2
34	RESISTOR	Resistor	33.2K	RESC0402M	R26, R36	Yageo	RC0402FR-0733K2L	2
35	RESISTOR	Resistor	57.6K	RESC0402M	R27, R37	Yageo	RC0402FR-0757K6L	2
36	RESISTOR	Resistor	100K	RESC0402M	R54	Yageo	RC0402FR-07100KL	1
37	RESISTOR	Resistor	47K	RESC0402M	R58, R59, R60, R61	Yageo	RC0402FR-0747KL	4
38	RESISTOR	Resistor	220R	RESC0402M	R65, R66, R67, R68, R69, R70	Yageo	RC0402FR-07220RL	6
39	RESISTOR	Resistor	4K7	RESC0402M	R91, R92, R96	Yageo	RC0402FR-074K7L	3
40	LDL1117	1.2A High PSRR Low-Dropout Linear Voltage Regulator		SOT-223	REG1	STMicroelectronics	LDL1117S33R	1
41	TLV743P	Capacitor-Free, 300mA, Low-Dropout Regulator	TLV743P	SOT-23-5	REG2	Texas Instruments	TLV74312PDBVR	1
42	TLV752	TLV752 Dual, 1-A, High-Accuracy, Adjustable-LDO in a Small-Size Package		WSON-10	REG3	Texas Instruments	TLV75201PDSQR	1
43	MICRO_SD_CON	1.10mm Pitch microSD Card Header with Detect Switch		104031-0811	SD1	Molex	104031-0811	1
44	T8F81	Trion T8 FPGA		BGA-81	U1	易灵思	T8F81C2	1
45	FT4232H-56Q	Quad High Speed USB To Multipurpose UART/MPSE IC, 56-pin QFN		QFN56_2_N	U2	FTDI	FT4232H-56Q-REEL	1
46	SP3003	TVS Diode Arrays, HDMI, DVI, USB2.0, IEEE 1394 Application	SP3003	SOT-553	U3	Littelfuse	SP3003-02XTG	1
47	93LC56BT	2K Microwire Compatible Serial EEPROM		SOT-23-6	U4	Microchip Technology	93LC56BT	1
48	W25Q128JVSIM	3V 8M-bit Serial Flash Memory		SOIC-8	U5	Winbond	W25Q128JVSIM	1
49	105017-0001	Micro-USB B Receptacle, Bottom Mount, Surface Mount		105017-0001	USB1	Molex	105017-0001	1
50	XTAL_SO3225	Crystal Oscillator, SO3225, 33.333M, +-50ppm(-40~+85), 3.3V	33.333MHz	XTAL-3225	Y1	ABRACON	ASE-33.333MHZ-L-C-T	1
51	XTAL_S3225A	Quantz Crystal, S3225A, 12M, +-20ppm, -+30ppm(-40~+85), 18pF, 100ohms	12MHz	XTAL-3225	Y2	ABRACON	ABM8G-12.000MHZ-18-D2Y-T	1



Disclaimers

易灵思 DOES NOT PROVIDES ANY WARRANTY OF ACCURACY, COMPLETENESS, MERCHANTABILITY OR NONINFRINGEMENT OF THIRD-PARTY RIGHTS ON THIS DOCUMENT. THE INFORMATION IN THIS DOCUMENT IS "AS IS". IN NO EVENT WILL 易灵思 BE LIABLE FOR ANY EXEMPLARY, SPECIAL, CONSEQUENTIAL, INDIRECT, OR INCIDENTAL DAMAGES, INCLUDING ANY LOSS OF DATA, LOST OF PROFITS, LOSS OF INFORMATION, LOSS OF LIFE OR BUSINESS INTERRUPTION, ARISING FROM YOUR USE OF THIS DOCUMENT.

易灵思 shall make changes to this document at any time without notification. 易灵思 assumes no obligation to correct any errors contained in this document or to advise any user of this document of any correction if such be made. 易灵思 advise its customers obtain the latest FPGA schematic before ordering so that no conflict of information correctness afterward.