



Firefly Compatible Camera Connector Daughter Card User Guide

FFCAM-DC-UG-v2.0
April 2020
www.elitestek.com



Contents

Introduction.....	3
What's in the Box?.....	3
Features.....	4
Headers.....	4
Installing Standoffs.....	6
Attaching Camera Connector Daughter Cards.....	7
Revision History.....	9

Introduction

The FireFly Compatible Camera add-on kit works together with the Trion® T20 MIPI Development Kit.

The kit includes the Firefly Compatible Camera Connector Daughter Card, which bridges between the Trion® T20 MIPI Development Board and an OV13850 camera module that is compatible with the Firefly RK3288 or RK3399 development board. The daughter card connects to the camera using a 30 pin flat cable. Additionally, the board has a 10 pin header for optional camera control pins.

Cameras that are compatible with this daughter card are available from:

- [Firefly](#)
- [AliExpress](#)
- [Taobao](#)



Note: For technical support using the camera, please refer to the camera vendor's web site.

Figure 1: Firefly Compatible Camera Connector Daughter Card

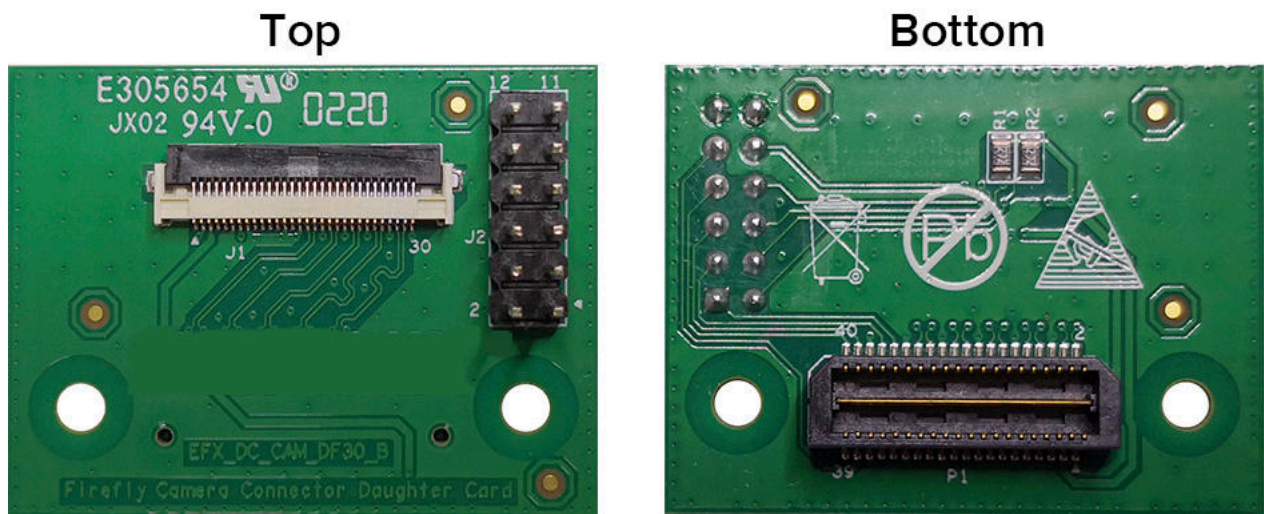

Warning: The board can be damaged without proper anti-static handling.

What's in the Box?

The FireFly Compatible Camera add-on kit includes:

- Firefly Compatible Camera Connector Daughter Card
- 2 standoffs
- 2 screws
- 2 nuts

Features

- Bridges 40 pin MIPI CSI-2 interface on Trion® T20 MIPI Development Board to 30 pin interface
- Pin to pin compatible with OV13850 camera modules that are compatible with the Firefly RK3288 or RK3399 development board
- Supports up to 1.5 Gbps on MIPI interface
- User selectable pins for optional camera functions
- Power supplied from the Trion® T20 MIPI Development Board; no external power required
 - Each pin supports up to 3 A

Headers

Table 1: FPC30 Camera Daughter Card Headers

Reference Designator	Description
P1	40 pin QTE header bringing MIPI signals, power, and 1.8 V GPIO pins from the Trion® T20 MIPI Development Board.
J1	30 pin flexible printed cable (FPC) connector for OV13850 camera modules that are compatible with the Firefly RK3288 or RK3399 development board.
J2	12 pin header for optional MIPI camera module signals.

Header P1 (Development Board Connector)

P1 is a 40 pin QTE header to connect the daughter card to the Trion® T20 MIPI Development Board. The header provides MIPI signals and power to the camera module.

Table 2: Development Board Connector (P1)

Pin Number	Pin Name	Description	Pin Number	Pin Name	Description
1	2V8_DF30	2.8 V power supply	2	MIPI_RXD_P0_DF30	Differential MIPI receiver lane 0
3	1V8_DF30	1.8 V power supply	4	MIPI_RXD_N0_DF30	
5	GND	Ground	6	GND	Ground
7	NC	No connect	8	MIPI_RXD_P1_DF30	Differential MIPI receiver lane 1
9	NC		10	MIPI_RXD_N1_DF30	
11	GND	Ground	12	GND	Ground
13	NC	No connect	14	MIPI_RXD_P2_DF30	Differential MIPI receiver lane 2
15	NC		16	MIPI_RXD_N2_DF30	
17	GND	Ground	18	GND	Ground
19	NC	No connect	20	MIPI_RXD_P3_DF30	Differential MIPI receiver lane 3
21	NC		22	MIPI_RXD_N3_DF30	
23	GND	Ground	24	GND	Ground
25	NC	No connect	26	MIPI_RXD_P4_DF30	Differential MIPI receiver lane 4
27	NC		28	MIPI_RXD_N4_DF30	

Pin Number	Pin Name	Description	Pin Number	Pin Name	Description
29	GND	Ground	30	GND	Ground
31	NC	No connect	32	GPIOL_69_1V8_SCL	1.8 V GPIO
33	NC		34	GPIOL_70_1V8_SDA	1.8 V GPIO
35	GND	Ground	36	GND	Ground
37	1V2_DF30	1.2 V power supply	38	GPIOL_71_1V8	1.8 V GPIO
39	GPIOL_73_1V8_REFCLK_DF30	1.8 V GPIO	40	GPIOL_72_1V8_DF30	1.8 V GPIO

Header J1 (FPC30 Connector)

J1 is a 30 pin flexible flat cable header for connecting to an OV13850 camera module that is compatible with the Firefly RK3288 or RK3399 development board.

Table 3: FPC30 Connector (J1)

Pin Number	Pin Name	Description	Pin Number	Pin Name	Description
1	1V8_DF30	1.8 V power supply	16	MIPI_RXD_P0_DF30	Differential MIPI receiver lane 0
2	2V8_DF30	2.8 V power supply	17	MIPI_RXD_N0_DF30	
3	1V2_DF30	1.2 V power supply	18	GND	Ground
4	1V8_DF30	1.8 V power supply	19	MIPI_RXD_P1_DF30	Differential MIPI receiver lane 1
5	NC	No connect	20	MIPI_RXD_N1_DF30	
6	GND	Ground	21	GND	Ground
7	2V8_DF30	2.8 V power supply	22	MIPI_RXD_P2_DF30	Differential MIPI receiver lane 2
8	GND	Ground	23	MIPI_RXD_N2_DF30	
9	SDA_DF30	Serial data for camera module	24	GND	Ground
10	SCL_DF30	Serial clock for camera module	25	MIPI_RXD_P3_DF30	Differential MIPI receiver lane 3
11	RST_DF30	Reset camera module	26	MIPI_RXD_N3_DF30	
12	GPIO_DF30	GPIO for camera module	27	GND	Ground
13	GND	Ground	28	MIPI_RXD_P4_DF30	Differential MIPI receiver lane 4
14	REFCLK_DF30	Reference clock for camera module	29	MIPI_RXD_N4_DF30	
15	GND	Ground	30	GND	Ground

Header J2 (Optional Camera Signals)

The J2 header has optional pins (SCL and SDA) that are used for MIPI Camera Command Set (CSS) transactions. When shunts are connected, the Trion® T20 MIPI Development Board controls these pins. Alternatively, you can control these pins with an external device by removing the shunt.

Table 4: Optional Camera Signals (J2)

Pin Number	Pin Name	Description	Pin Number	Pin Name	Description
1	GPIOL_69_1V8_SCL_DF30	1.8 V I/O from development board	2	SCL_DF30	Camera serial clock
3	GPIOL_70_1V8_SDA_DF30		4	SDA_DF30	Camera data
5	GPIOL_71_1V8_DF30		6	RST_DF30	Camera reset
7	GPIOL_72_1V8_DF30		8	GPIO_DF30	Camera GPIO
9	GPIOL_73_1V8_REFCLK_DF30		10	REFCLK_DF30	Camera reference clock
11	GND	Ground	12	GND	Ground

Installing Standoffs

Before using the board, attach the standoffs with the screws provided in the kit.



Warning: You can damage the board if you over tighten the screws. Tighten all screws to a torque between 4 ± 0.5 kgf/cm and 5 ± 0.5 kgf/cm.

Attaching Camera Connector Daughter Cards

The camera connector daughter card attaches to the high-speed MIPI TX or RX headers.

Figure 2: Attaching Camera Connector Daughter Cards (T20 MIPI Board)

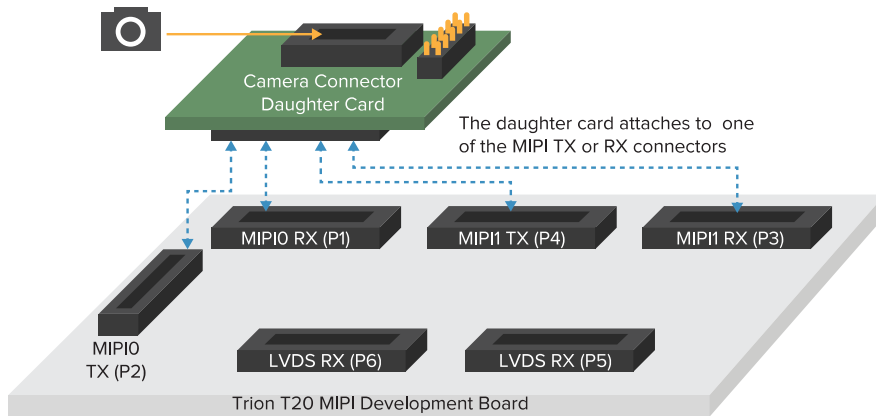

Figure 3: Attaching Camera Connector Daughter Cards (T120 BGA324 Board)

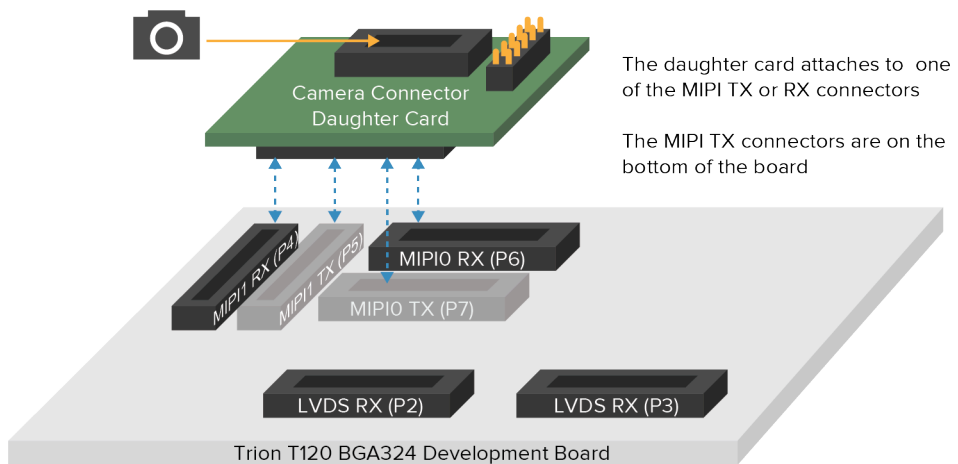
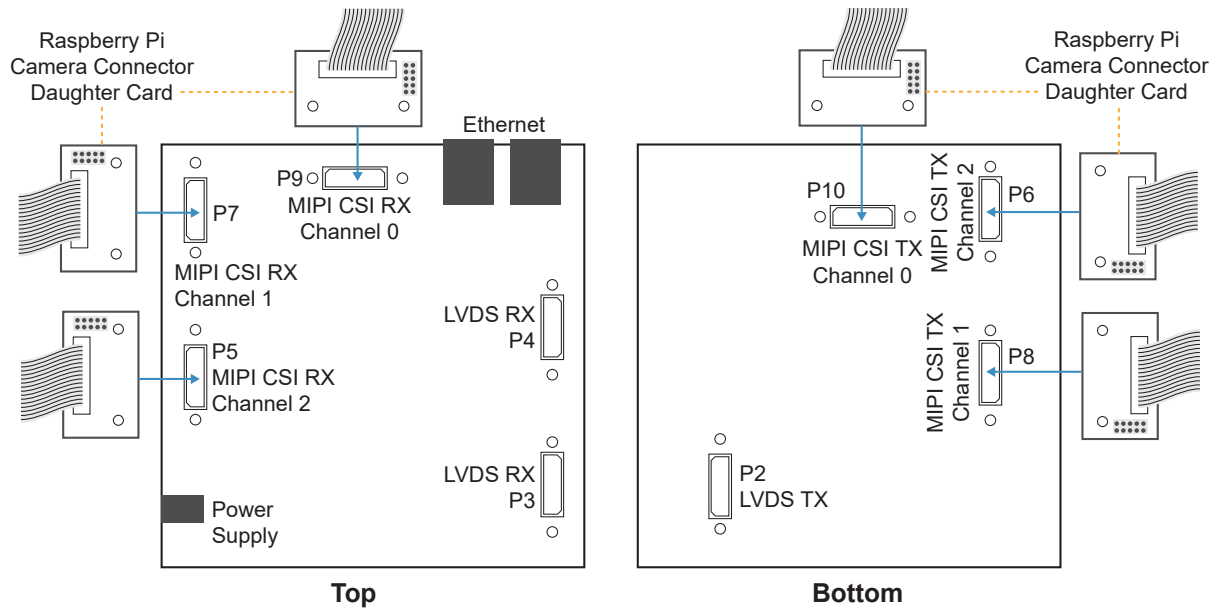

Figure 4: Attaching Camera Connector Daughter Cards (T120 BGA576 Board)

To connect a daughter card:

1. Remove power from the Trion® T20 MIPI Development Board.
2. Attach standoffs to the daughter card.
3. Attach the daughter card to the 40-pin header on the board.
4. Connect the camera module or computer to the daughter card using a ribbon cable.
5. Power up the board.

Revision History

Table 5: Revision History

Date	Version	Description
April 2020	2.0	Updated daughter card photo and header numbering. Added figure for connecting to the T120 BGS324 development board.
January 2020	1.0	Initial release.