



Leopard Imaging Camera Connector Daughter Card User Guide

LICAM-DC-UG-v2.0
April 2020
www.elitestek.com



Contents

Introduction.....	3
What's in the Box?.....	3
Features.....	4
Headers.....	4
Installing Standoffs.....	6
Attaching Camera Connector Daughter Cards.....	7
Revision History.....	9

Introduction

The kit includes the Leopard Imaging Camera Connector Daughter Card, which bridges between the Trion® T20 MIPI Development Board and Leopard Imaging CSI-2 camera modules. The daughter card connects to any Leopard Imaging CSI-2 camera using a 30 pin IPEX cable. Additionally, the board has a 10 pin header for optional camera control pins.



Note: When using this card, you should use the external power adapter instead of the USB cable for power.

Figure 1: Leopard Imaging Camera Connector Daughter Card

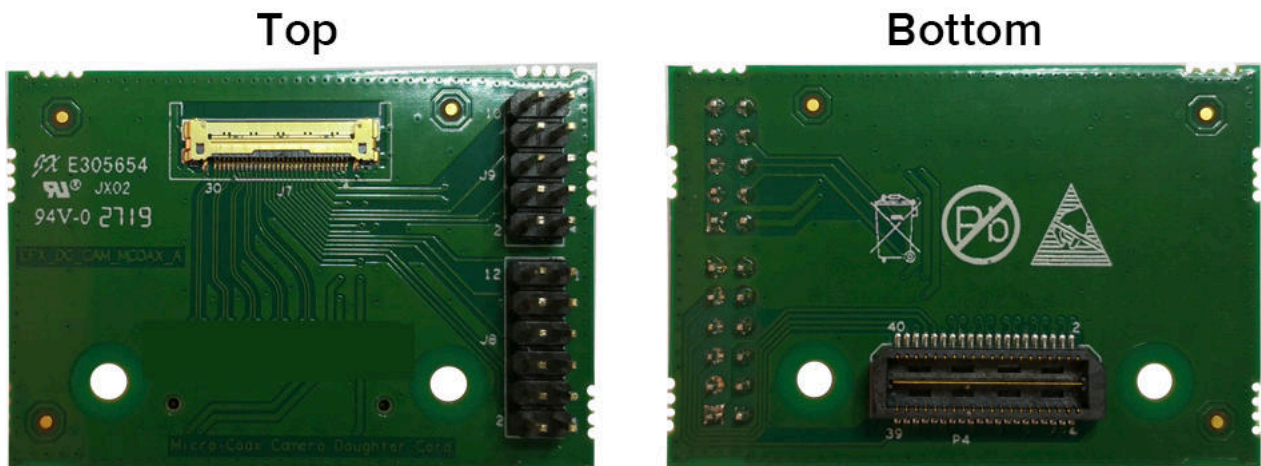

Warning: The board can be damaged without proper anti-static handling.

What's in the Box?

The Leopard Imaging Camera Connector add-on kit includes:

- Leopard Imaging Camera Connector Daughter Card
- 2 standoffs
- 2 screws
- 2 nuts

Features

- Bridges 40 pin MIPI CSI-2 interface on Trion® T20 MIPI Development Board to 30 pin interface
- Pin to pin compatible with Leopard Imaging cameras
- Supports up to 1.5 Gbps on MIPI interface
- User selectable pins for optional camera functions
- Supports a camera power-up sequence controlled by the development board
- Power supplied from the Trion® T20 MIPI Development Board; no external power required
 - Each pin supports up to 3 A



Note: For technical support using Leopard Imaging cameras, please refer to their web site at www.leopardimaging.com.

Headers

Table 1: Leopard Imaging Camera Connector Daughter Card Headers

Reference Designator	Description
P4	40 pin QTE header bringing MIPI signals, power, and 1.8 V GPIO pins from the Trion® T20 MIPI Development Board.
J7	30 pin IPEX connector for Leopard Imaging CSI-2 cameras.
J8, J9	12 pin and 10 pin headers for optional camera module signals.

Header P4 (Development Board Connector)

P4 is a 40 pin QTE header to connect the daughter card to the Trion® T20 MIPI Development Board. The header provides MIPI signals and power to the camera module.

Table 2: Development Board Connector (P4)

Pin Number	Pin Name	Description	Pin Number	Pin Name	Description
1	5V0_IPEX	5.0 V power supply	2	MIPI_RXD_P0_IPEX	Differential MIPI Receiver Lane 0
3	3V3_IPEX	3.3 V power supply	4	MIPI_RXD_N0_IPEX	
5	GND	Ground	6	GND	Ground
7	NC	No connect	8	MIPI_RXD_P1_IPEX	Differential MIPI Receiver Lane 1
9	NC		10	MIPI_RXD_N1_IPEX	
11	GND	Ground	12	GND	Ground
13	NC	No connect	14	MIPI_RXD_P2_IPEX	Differential MIPI Receiver Lane 2
15	NC		16	MIPI_RXD_N2_IPEX	
17	GND	Ground	18	GND	Ground
19	NC	No connect	20	MIPI_RXD_P3_IPEX	Differential MIPI Receiver Lane 3
21	NC		22	MIPI_RXD_N3_IPEX	
23	GND	Ground	24	GND	Ground

Pin Number	Pin Name	Description	Pin Number	Pin Name	Description
25	NC	No connect	26	MIPI_RXD_P4_IPEX	Differential MIPI Receiver Lane 4
27	NC		28	MIPI_RXD_N4_IPEX	
29	GND	Ground	30	GND	Ground
31	NC	No connect	32	GPIOL_69_1V8_SCL_IPEX	1.8 V GPIO
33	NC		34	GPIOL_70_1V8_SDA_IPEX	1.8 V GPIO
35	GND	Ground	36	GND	Ground
37	1V2_IPEX	1.2 V power supply	38	GPIOL_71_1V8_IPEX	1.8 V GPIO
39	GPIOL_73_1V8_REFCLK_IPEX	1.8 V GPIO	40	GPIOL_72_1V8_IPEX	1.8 V GPIO

Header J7 (IPEX Connector)

J7 is a 30 IPEX header for connecting to a Leopard Imaging camera module.

Table 3: IPEX Connector (J7)

Pin Number	Pin Name	Description	Pin Number	Pin Name	Description
1	3V3_IPEX	3.3 V power supply	16	RST_IPEX	Camera reset
2	3V3_IPEX		17	SDA_IPEX	Camera serial data
3	3V3_IPEX		18	SCL_IPEX	Camera serial clock
4	5V0_IPEX	5.0 V power supply	19	ADDR_IPEX	Camera address
5	2V8_IPEX	2.8 V power supply	20	MIPI_RXD_N4_IPEX	Differential MIPI Receiver Lane 4
6	1V8_IPEX	1.8 V power supply	21	MIPI_RXD_P4_IPEX	
7	1V2_IPEX	1.2 V power supply	22	MIPI_RXD_N3_IPEX	Differential MIPI Receiver Lane 3
8	1V2_IPEX		23	MIPI_RXD_P3_IPEX	
9	GPIO00_IPEX	Optional GPIO 00	24	MIPI_RXD_N2_IPEX	Differential MIPI Receiver Lane 2
10	TEST_IPEX	Camera test pin	25	MIPI_RXD_P2_IPEX	
11	GPIO01_IPEX	Optional GPIO 01	26	GDN	Ground
12	XVS_IPEX	Vertical sync	27	MIPI_RXD_N1_IPEX	Differential MIPI Receiver Lane 1
13	XHS_IPEX	Horizontal sync	28	MIPI_RXD_P1_IPEX	
14	FLASH_IPEX	Flash signal	29	MIPI_RXD_N0_IPEX	Differential MIPI Receiver Lane 0
15	REFCLK_IPEX	Camera reference clock	30	MIPI_RXD_P0_IPEX	

Headers J8 and J9 (Optional Camera Signals)

The J8 and J9 headers have optional pins.

When you connect a shunt to J8, the Trion® T20 MIPI Development Board controls the pins in this header. Alternatively, you can control these pins with an external device by removing the shunt.

Table 4: Optional Camera Signals (J8)

Pin Number	Pin Name	Description	Pin Number	Pin Name	Description
1	GPIOL_69_1V8_SCL_IPEX	1.8 V I/O from development kit	2	SCL_IPEX	Serial clock
3	GPIOL_70_1V8_SDA_IPEX		4	SDA_IPEX	Serial data
5	GPIOL_71_1V8_IPEX		6	RST_IPEX	Reset
7	GPIOL_72_1V8_IPEX		8	FLASH_IPEX	Flash
9	GPIOL_73_1V8_REFCLK_IPEX		10	REFCLK_IPEX	Reference clock
11	GND	Ground	12	GND	Ground

Table 5: Optional Camera Signals (J9)

Pin Number	Pin Name	Description	Pin Number	Pin Name	Description
1	2V8_IPEX	2.8 V supply	2	1V8_IPEX	1.8 V supply
3	TEST_IPEX	Test pin for Leopard Imaging	4	ADDR_IPEX	Serial address pin
5	GPIO01_IPEX	Optional GPIO 00	6	XHS_IPEX	Horizontal sync
7	GPIO00_IPEX	Optional GPIO 01	8	XVS_IPEX	Vertical sync
9	GND	Ground	10	GND	Ground

Installing Standoffs

Before using the board, attach the standoffs with the screws provided in the kit.



Warning: You can damage the board if you over tighten the screws. Tighten all screws to a torque between 4 ± 0.5 kgf/cm and 5 ± 0.5 kgf/cm.

Attaching Camera Connector Daughter Cards

The camera connector daughter card attaches to the high-speed MIPI TX or RX headers.

Figure 2: Attaching Camera Connector Daughter Cards (T20 MIPI Board)

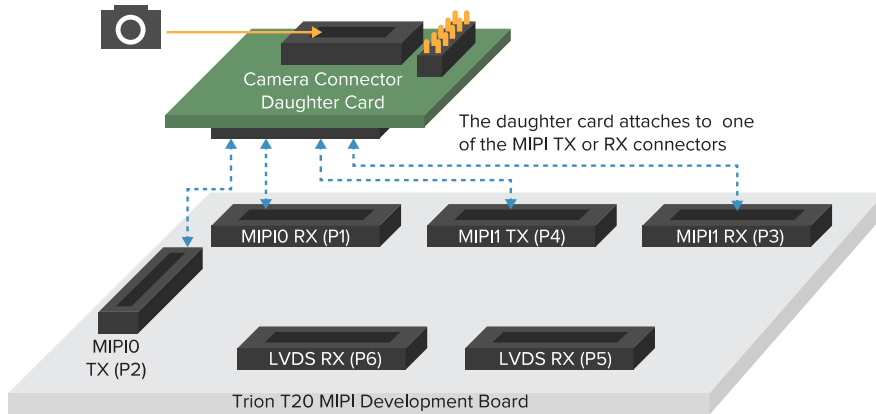

Figure 3: Attaching Camera Connector Daughter Cards (T120 BGA324 Board)

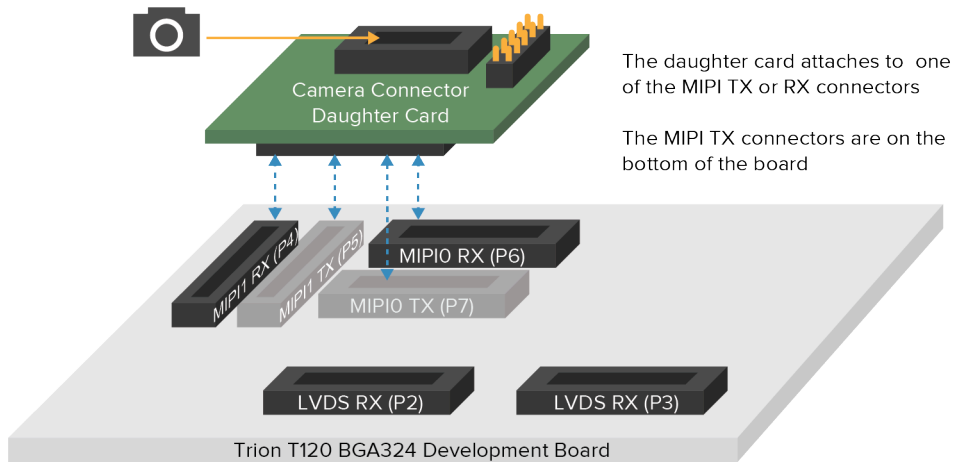
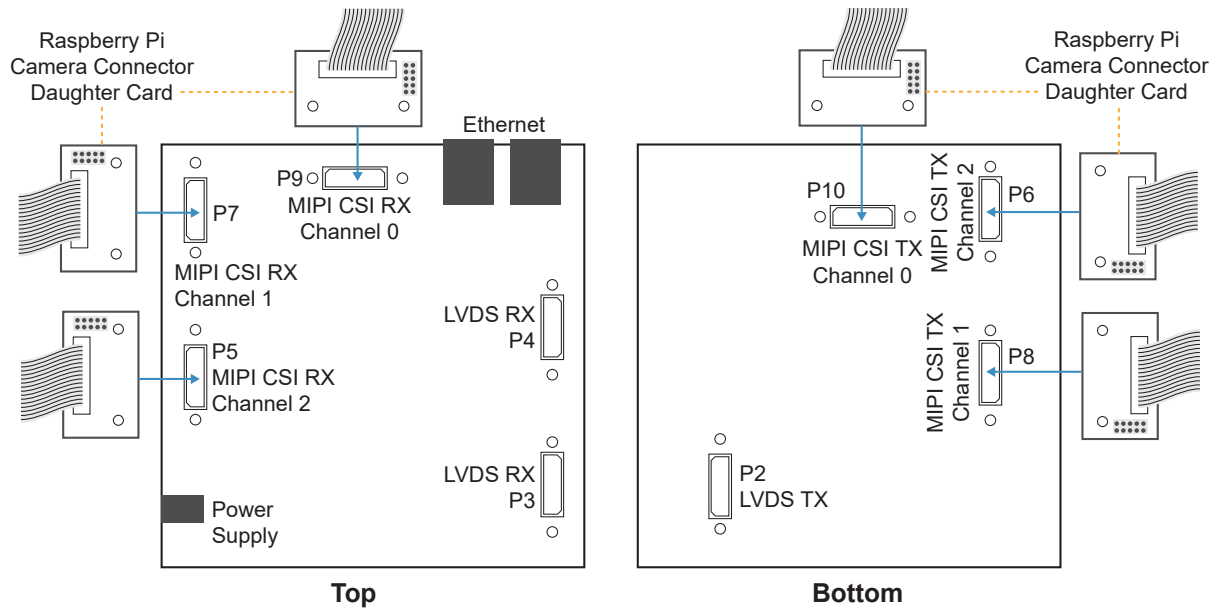

Figure 4: Attaching Camera Connector Daughter Cards (T120 BGA576 Board)



To connect a daughter card:

1. Remove power from the Trion® T20 MIPI Development Board.
2. Attach standoffs to the daughter card.
3. Attach the daughter card to the 40-pin header on the board.
4. Connect the camera module or computer to the daughter card using a ribbon cable.
5. Power up the board.

Revision History

Table 6: Revision History

Date	Version	Description
April 2020	2.0	Added figure for connecting to the T120 BGS324 development board.
January 2020	1.0	Initial release.