

MIPI AND LVDS EXPANSION DAUGHTER CARD

CONTENTS

PAGE 01 - TABLE OF CONTENTS
PAGE 02 - BLOCK DIAGRAM
PAGE 03 - QTE to 2.54MM HEADER CONVERTER

REVISION HISTORY

1.0 4/17/2020 KCL EE Initial Creation (Originate
from Document ESTB-00002-2)

All material must comply with:

1. The requirements of the European Union RoHS 2 Directive 2017/2102 (Amendment to 2011/65/EU) with no exceptions unless authorized.
2. The requirements of EC 1907/2006 and not contain any of the Substances of Very High Concern (SVHC) listed under the latest REACH requirements. (Amendments EU 2017/999, EU 2017/1510, EU 2018/35).

No changes to 易灵思 bill of materials is allowed unless approved in writing by 易灵思 Product Engineering Group. These changes will be maintained in the document revision history via ECN.

易灵思 1204 Qianhai Yidu Building, No. 99 Gangcheng Street, Nanshan District, Shenzhen, Guangdong, China			
Copyright (c) 2019 All Rights Reserved			
Title TABLE OF CONTENTS			
Size	Document Number ETSB-00013-2	Rev	1.0
Date:	Thursday, December 17, 2020		Sheet 1 of 3



易灵思 1204 Qianhai Yidu Building, No. 99 Gangcheng Street, Nanshan District, Shenzhen, Guangdong, China		
Copyright (c) 2019 All Rights Reserved		
易灵思		
Title		
BLOCK DIAGRAM		
Size	Document Number	Rev
	ETSB-00013-2	1.0
Date:	Friday, April 17, 2020	Sheet 2 of 3

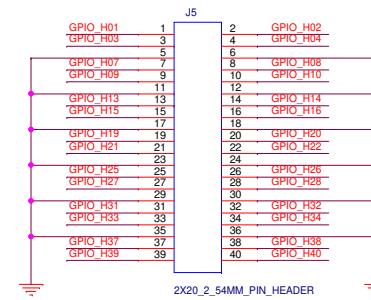
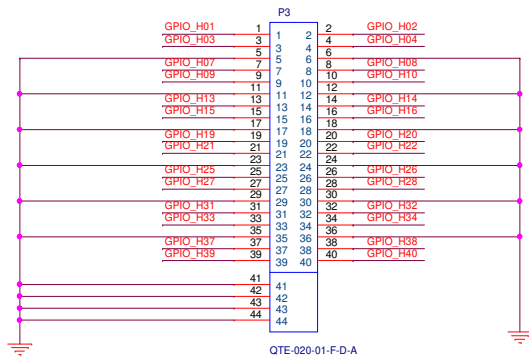



Item	Quantity	Reference	Part	Datasheet	Description	PCB Footprint	Brand	Manufacturer Part No
1	1	J5	2X20 2.54MM PIN HEADER	E0004	2 x 20 Header (2.54 MM Pitch)	Thru-Hole	MULTICOMP	2213S-40G
2	1	P3	QTE-020-01-F-D-A	A0100/A0100-1	40 Ways Board to Board & Mezzanine Connectors 0.80 mm Q Strip High-Speed Ground Plane Terminal Strip	SMD	Samtec	QTE-020-01-F-D-A



Disclaimers

易灵思 DOES NOT PROVIDES ANY WARRANTY OF ACCURACY, COMPLETENESS, MERCHANTABILITY OR NONINFRINGEMENT OF THIRD-PARTY RIGHTS ON THIS DOCUMENT. THE INFORMATION IN THIS DOCUMENT IS “AS IS”. IN NO EVENT WILL 易灵思 BE LIABLE FOR ANY EXEMPLARY, SPECIAL, CONSEQUENTIAL, INDIRECT, OR INCIDENTAL DAMAGES, INCLUDING ANY LOSS OF DATA, LOST OF PROFITS, LOSS OF INFORMATION, LOSS OF LIFE OR BUSINESS INTERRUPTION, ARISING FROM YOUR USE OF THIS DOCUMENT.

易灵思 shall make changes to this document at any time without notification. 易灵思 assumes no obligation to correct any errors contained in this document or to advise any user of this document of any correction if such be made. 易灵思 advise its customers obtain the latest FPGA schematic before ordering so that no conflict of information correctness afterward.