

CORAL CAMERA DAUGHTER CARD

CONTENTS

PAGE 01 - TABLE OF CONTENTS
PAGE 02 - CORAL CAMERA INTERFACE

DOCUMENT VERSION HISTORY

VER	DATE	EDITOR	DESCRIPTION
1.0	11/03/22	CFLEUNG	Rev A1 initial release

易灵思		Copyright (C) 2023 All Rights Reserved	
1204 Qianhai Yidu Building, No. 99 Gangcheng Street, Nanshan District, Shenzhen, Guangdong, China			
Title		易灵思	
TABLE OF CONTENTS			
Size	Document Number	Rev	
A4	CORAL-CAM-CON-DC-SCHM	A1	
Date:	Sunday, March 12, 2023	Sheet	1 of 2
	2		1

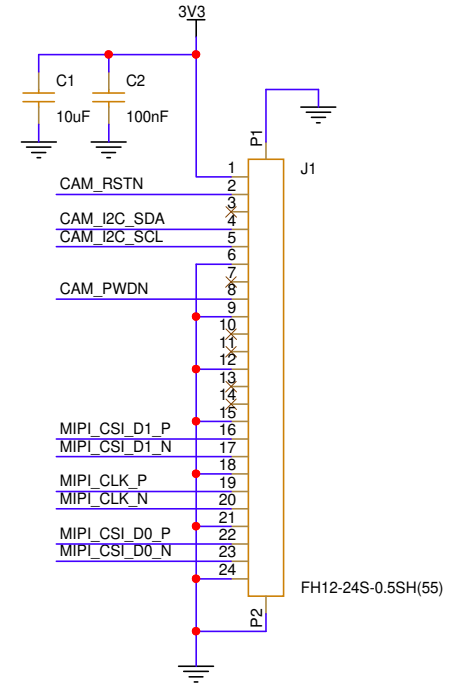
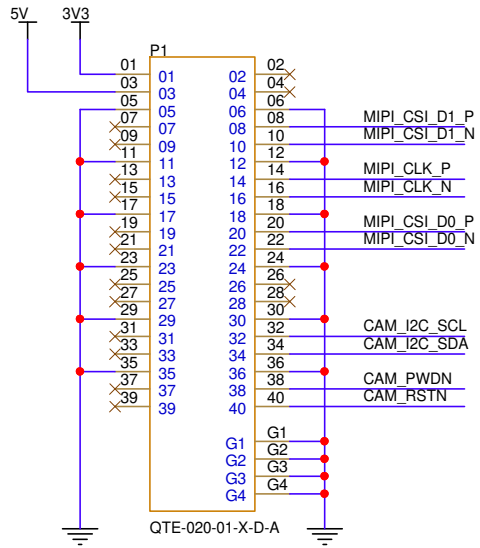
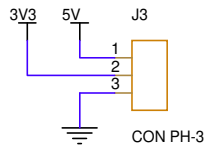
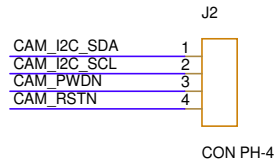



Item	Qty	Part Type	Description	Value	Reference	Footprint	Manufacturing PN
1	1	CAPACITOR	X7R, 10%, 16V	10 μ F	C1	C0603	
2	1	CAPACITOR	X7R, 10%, 50V	100nF	C2	C0402	
3	1	CONNECTOR	0.5mm Pitch, Height 2.0mm Bottom Contact, Front Flip	FH12-24S-0.5SH(55)	J1	FH12-24S-05SH	FH12-24S-0.5SH(55)
4	1	CONNECTOR		CON PH-4	J2	PH2M54_4P1R	DNI
5	1	CONNECTOR		CON PH-3	J3	PH2M54_3P1R	DNI
6	1	CONNECTOR	Q Strip® High-Speed Ground Plane Header, 20 0.80mm Pitch	QTE-020-01-X-D-A	P1	QTE-020-01-L-D-A	QTE-020-01-L-D-A



Disclaimers

易灵思 DOES NOT PROVIDES ANY WARRANTY OF ACCURACY, COMPLETENESS, MERCHANTABILITY OR NONINFRINGEMENT OF THIRD-PARTY RIGHTS ON THIS DOCUMENT. THE INFORMATION IN THIS DOCUMENT IS “AS IS”. IN NO EVENT WILL 易灵思 BE LIABLE FOR ANY EXEMPLARY, SPECIAL, CONSEQUENTIAL, INDIRECT, OR INCIDENTAL DAMAGES, INCLUDING ANY LOSS OF DATA, LOST OF PROFITS, LOSS OF INFORMATION, LOSS OF LIFE OR BUSINESS INTERRUPTION, ARISING FROM YOUR USE OF THIS DOCUMENT.

易灵思 shall make changes to this document at any time without notification. 易灵思 assumes no obligation to correct any errors contained in this document or to advise any user of this document of any correction if such be made. 易灵思 advise its customers obtain the latest FPGA schematic before ordering so that no conflict of information correctness afterward.