



Ti60 Data Sheet

DSTi60-v3.2
May 2024
www.elitestek.com



Contents

Introduction.....	3
Features.....	3
Available Package Options.....	4
Device Core Functional Description.....	5
XLR Cell.....	6
Embedded Memory.....	7
True Dual-Port Mode.....	7
Simple Dual-Port Mode.....	7
DSP Block.....	8
Clock and Control Network.....	9
Clock Sources that Drive the Global and Regional Networks.....	10
Driving the Global Network.....	11
Driving the Regional Network.....	16
Driving the Local Network.....	17
Device Interface Functional Description.....	19
Interface Block Connectivity.....	19
GPIO.....	20
Features for HVIO and HSIO Configured as GPIO.....	21
HVIO.....	24
HSIO.....	25
I/O Banks.....	39
Oscillator.....	39
PLL.....	40
Dynamic Phase Shift.....	43
SPI Flash Memory.....	44
HyperRAM.....	45
Single-Event Upset Detection.....	46
Internal Reconfiguration Block.....	46
Security Feature.....	47
Power Sequence.....	49
Power-Up Sequence (No VQPS).....	49
Power-Up Sequence (VQPS).....	50
Power-Down Sequence.....	51
Power Supply Current Transient.....	51
Configuration.....	52
Supported FPGA Configuration Modes.....	53
Characteristics and Timing.....	54
DC and Switching Characteristics.....	54
HSIO Electrical and Timing Specifications.....	60
PLL Timing and AC Characteristics.....	63
Configuration Timing.....	64
Pinout Description.....	68
Configuration Pins.....	70
Ti60 Interface Floorplan.....	73
Efinity Software Support.....	74
Ordering Codes.....	74
Revision History.....	75

Introduction

The TJ-Series Ti60 FPGA features the high-density, low-power Elitestek® Quantum® compute fabric wrapped with an I/O interface in a small footprint package for easy integration. Ti60 FPGAs are designed for highly integrated mobile and edge devices that need low power, a small footprint, and a multitude of I/Os. With ultra-low power Ti60 FPGAs, designers can build products that are always on, providing enhanced capabilities for applications such as mobile, edge, AI IoT, and sensor fusion.

Features

- High-density, low-power Quantum® compute fabric
- Built on TSMC 16 nm process
- 10-kbit high-speed, embedded SRAM, configurable as single-port RAM, simple dual-port RAM, true dual-port RAM, or ROM
- High-performance DSP blocks for multiplication, addition, subtraction, accumulation, and up to 15-bit variable-right-shifting
- Versatile on-chip clocking
 - Low-skew global network supporting 32 clock or control signals
 - Regional and local clock networks
 - PLL support
- FPGA interface blocks
 - High-voltage I/O (HVIO) (1.8, 2.5, 3.3 V)
 - High-speed I/O (HSIO), configurable as:
 - LVDS, subLVDS, Mini-LVDS, and RSDS (RX, TX, and bidirectional), up to 1.5 Gbps
 - MIPI lane I/O (DSI and CSI) in high-speed (HS) low-power (LP) modes, up to 1.5 Gbps
 - Single-ended and differential I/O
 - PLL
 - Oscillator
- Flexible device configuration
 - Standard SPI interface (active, passive, and daisy chain⁽¹⁾)
 - JTAG interface
 - Supports internal reconfiguration
- Single-event upset (SEU) detection feature
- Fully supported by the Efinity® software, an RTL-to-bitstream compiler
- Optional security feature⁽²⁾
 - Asymmetric bitstream authentication using RSA-4096
 - Bitstream encryption/decryption using AES-GCM

Table 1: Ti60 FPGA Resources

Logic Elements (LEs)	eXchangeable Logic and Routing (XLR) Cells		Global Clock and Control Signals	Embedded Memory (Mbits)	Embedded Memory Blocks (10 Kbits)	Embedded DSP Blocks
	Total	SRL8 ⁽³⁾				
62,016	60,800	14,720	Up to 32	2.6	256	160

⁽¹⁾ Daisy-chain is not supported in the F100 and F100S3F2 packages.

⁽²⁾ The security feature is not supported for W64 packages. See **PCN-2405-002** for details.

⁽³⁾ Number of XLR that can be configured as shift register with 8 maximum taps.

Table 2: Ti60 Package-Dependent Resources

Resource		W64	F100 F100S3F2	F225	F256
Single-ended GPIO (Max)	HVIO (1.8, 2.5, 3.0, 3.3 V LVCMOS, 3.0, 3.3 V LVTTTL)	–	–	23	27
	HSIO (1.2, 1.35, 1.5, 1.8 V LVCMOS, HSTL and SSTL)	34	61	140	142
Differential GPIO (Max)	HSIO (LVDS, Differential HSTL, SSTL, MIPI TX Data and Clock Lanes)	17	30	70	71
	HSIO (MIPI RX Data Lanes)	8	21	58	59
	HSIO (MIPI RX Clock Lanes)	2	3	12	12
Global clock or control signals from GPIO pins		3	8	15	16
PLLs		2	3	4	4



Learn more: Refer to the TJ-Series Packaging User Guide for the package outlines and markings.

Available Package Options

Table 3: Available Packages

Package	Dimensions (mm x mm)	Pitch (mm)
64-ball WLCSP	3.5 x 3.4	0.4
100-ball FBGA	5.5 x 5.5	0.5
225-ball FBGA	10 x 10	0.65
256-ball FBGA	13 x 13	0.8

Device Core Functional Description

Ti60 FPGAs feature an eXchangeable Logic and Routing (XLR) cell that Elitestek® has optimized for a variety of applications. TJ-Series FPGAs contain LEs that are constructed from XLR cells. Each FPGA in the TJ-Series family has a custom number of building blocks to fit specific application needs. As shown in the following figure, the FPGA includes I/O ports on all four sides, as well as columns of LEs, memory, and DSP blocks. A control block within the FPGA handles configuration.

Figure 1: Ti60 FPGA Block Diagram

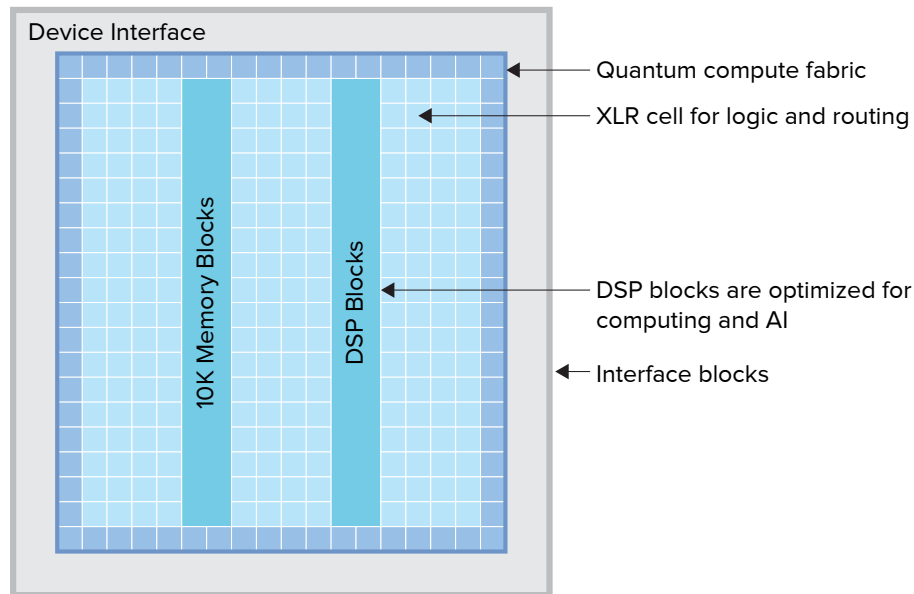

Interface blocks include GPIO, LVDS, PLL and MIPI lane I/O.

XLR Cell

The eXchangeable Logic and Routing (XLR) cell is the basic building block of the Quantum[®] architecture. The Elitestek[®] XLR cell combines logic and routing and supports both functions. This unique innovation greatly enhances the transistor flexibility and utilization rate, thereby reducing transistor counts and silicon area significantly.



Learn more: For more detailed on the advantages the XLR cell brings to TJ-Series FPGAs, read the Why the XLR Cell is a Big Deal White Paper.

The XLR cell functions as:

- A 4-input LUT that supports any combinational logic function with four inputs.
- A simple full adder.
- An 8-bit shift register that can be cascaded.
- A fracturable LUT or full adder.

The logic cell includes an optional flipflop. You can configure multiple logic cells to implement arithmetic functions such as adders, subtractors, and counters.

Figure 2: Logic Cell Functions

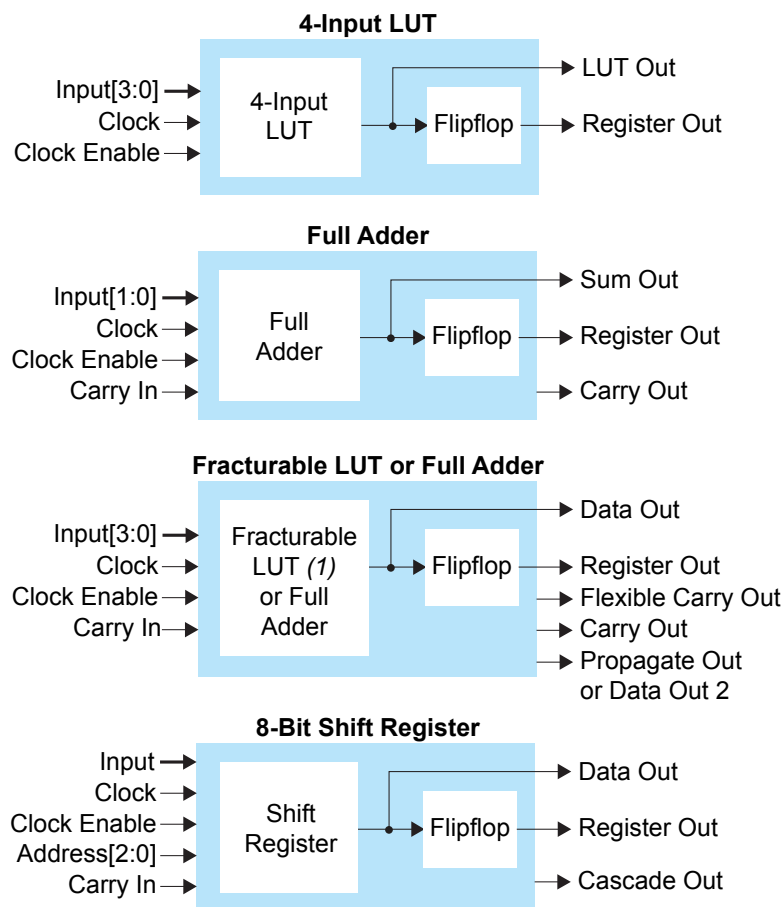

1. The fracturable LUT is a combination of a 3-input LUT and a 2-input LUT. They share 2 of the same inputs.



Learn more: Refer to the Quantum[®] TJ-Series Primitives User Guide for details on the TJ-Series logic cell primitives.

Embedded Memory

The core has 10-kbit high-speed, synchronous, embedded SRAM memory blocks. Memory blocks can operate as single-port RAM, simple dual-port RAM, true dual-port RAM, or ROM. You can initialize the memory content during configuration. The Efinity® software includes a memory cascading feature to connect multiple blocks automatically to form a larger array. This feature enables you to instantiate deeper or wider memory modules.



Note: The block RAM content is random and undefined if it is not initialized.

The read and write ports support independently configured data widths, an address enable, and an output register reset. The simple dual-port mode also supports a write byte enable.



Learn more: Refer to the Quantum® TJ-Series Primitives User Guide for details on the RAM configuration.

True Dual-Port Mode

The memory read and write ports have the following modes for addressing the memory (depth x width):

1024 x 8	2048 x 4	4096 x 2
8192 x 1	1024 x 10	2048 x 5

Figure 3: RAM Block Diagram (True Dual-Port Mode)

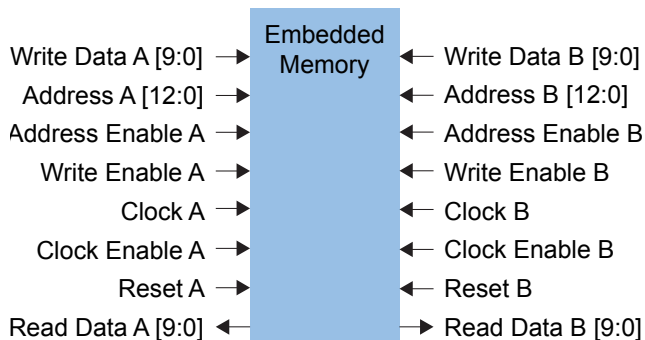

Simple Dual-Port Mode

The memory read and write ports have the following modes for addressing the memory (depth x width):

512 x 16	1024 x 8	2048 x 4	4096 x 2
8192 x 1	512 x 20	1024 x 10	2048 x 5

Figure 4: Simple Dual-Port Mode RAM Block Diagram (512 x 20 Configuration)

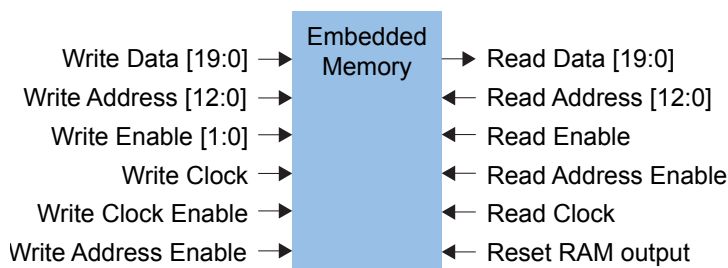

DSP Block

The FPGA has high-performance, complex DSP blocks that can perform multiplication, addition, subtraction, accumulation, and 4-bit variable right shifting. The 4-bit variable right shift supports one lane in normal mode, two lanes in dual mode and four lanes in quad mode. Each DSP block has four modes, which support the following multiplication operations:

- Normal—One 19 x 18 integer multiplication with 48-bit addition/subtraction.
- Dual—One 11 x 10 integer multiplication and one 8 x 8 integer multiplication with two 24-bit additions/subtractions.
- Quad—One 7 x 6 integer multiplication and three 4 x 4 integer multiplications with four 12-bit additions/subtractions.



Important: The 7 x 6 Quad mode output is truncated to 12-bit.

- Float—One fused-multiply-add/subtract/accumulate (FMA) BFLOAT16 multiplication.

The integer multipliers can represent signed or unsigned values based on the `SIGNED` parameter. When multiple `EFX_DSP12` or `EFX_DSP24` primitives are mapped to the same DSP block, they must have the same `SIGNED` value. The inputs to the multiplier are the A and B data inputs. Optionally, you can use the result of the multiplier in an addition or subtraction operation.

Figure 5: DSP Block Diagram

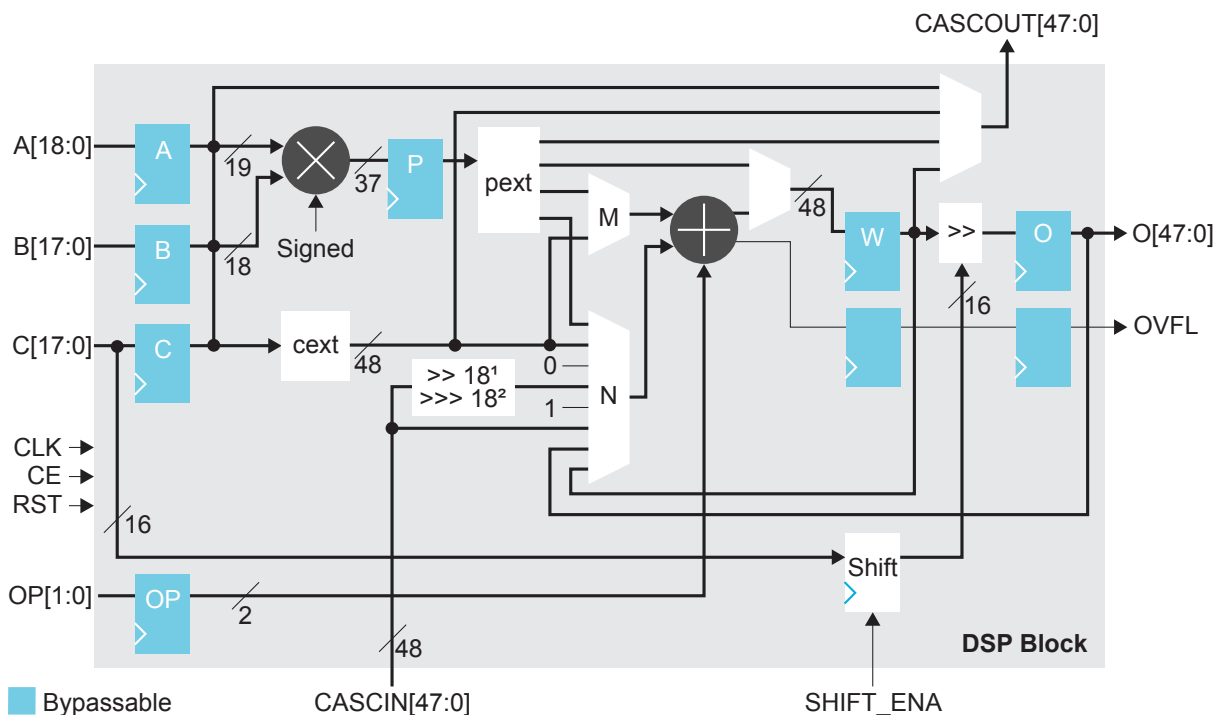

1. Logical right-shift-by-18.
2. Arithmetic right-shift-by-18.



Learn more: Refer to the Quantum® TJ-Series Primitives User Guide for more information about the TJ-Series DSP block primitives.

Clock and Control Network

The clock and control network is distributed through the FPGA to provide clocking for the core's LEs, memory, DSP blocks, I/O blocks, and control signals. The FPGA has 32 global signals that can be used as either clocks or control signals. The global signals are balanced trees that feed the whole FPGA.

The FPGA also has regional signals that can only reach certain FPGA regions, including the top or bottom edges. The FPGA has 4 regional networks for the core, right interface, and left interface blocks. The top and bottom interface blocks have 1 regional clock network each. You can drive the right and left sides of each region independently. Each region also has a local network of clock signals that can only be used in that region.

The core's global buffer (GBUF) blocks drive the global and regional networks. Signals from the core and interface can drive the GBUF blocks.

Each network has dedicated enable logic to save power by disabling the clock tree. The logic dynamically enables/disables the network and guarantees no glitches at the output.

Figure 6: Global and Regional Clock Network Overview

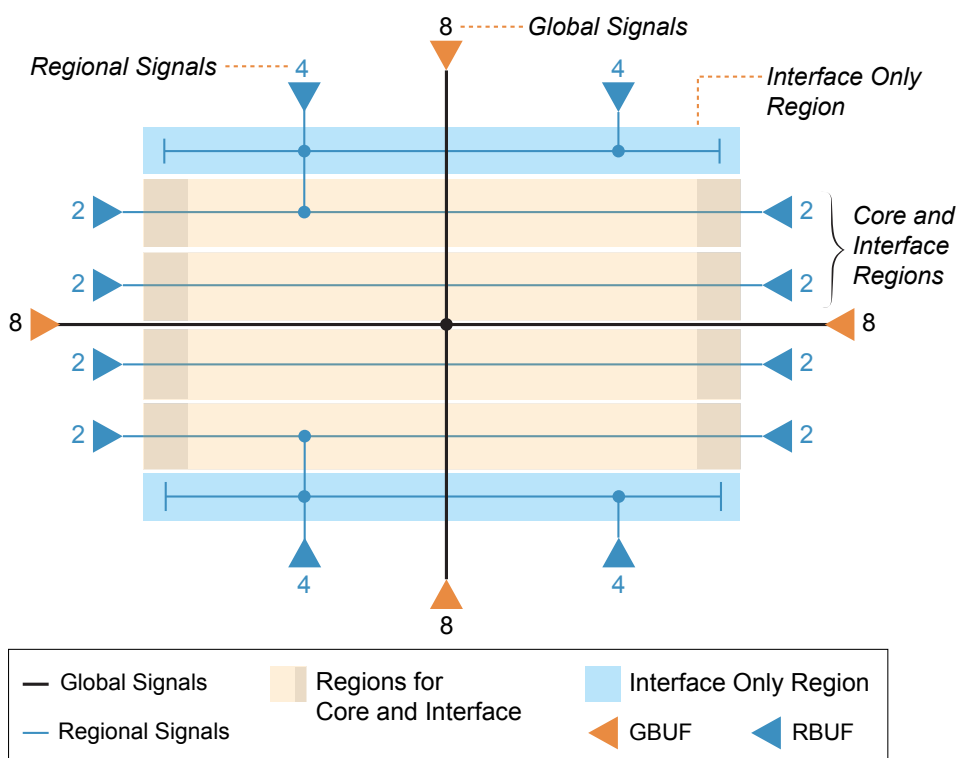

Clock Sources that Drive the Global and Regional Networks

The TJ-Series global and regional networks are highly flexible and configurable. Clock sources can come from interface blocks, such as GPIO or PLLs, or from the core fabric.

Table 4: Clock Sources that Drive the Global and Regional Networks

Source	Description
GPIO	Supports GCLK and RCLK. (Only the P resources support this connection type).
LVDS RX	Supports GCLK and RCLK.
MIPI RX Lane (configured as clock lane)	Supports GCLK (default) and RCLK. You can only use resources that are identified as clocks.
PLL	Output clocks 0 - 3 connect to the global network. Output clock 4 only connects to the regional network in the top or bottom interface regions (depending on the location of the PLL) and can only drive interface blocks on the top or bottom of the FPGA. Refer to P16 Driving the Regional Network for the PLL clocks that drive the regional network.
Oscillator	Connects to global buffer.
Core	Signals from the core logic can drive the global or regional network.

Driving the Global Network

You can access the global clock network using the global clock GPIO pins, PLL outputs, oscillator output, and core-generated clocks.

A clock multiplexing network controls which interface blocks can drive the global and regional networks. Eight of the clock multiplexers are dynamic (two on each side of the FPGA), allowing you to change which clock drives the global signal in user mode.



Learn more: Refer to the Quantum® TJ-Series Primitives User Guide for information on how to configure the global and regional clock networks.

The following figure shows the global network clock sources graphically.

Figure 7: Clock Sources that Drive the Global Network

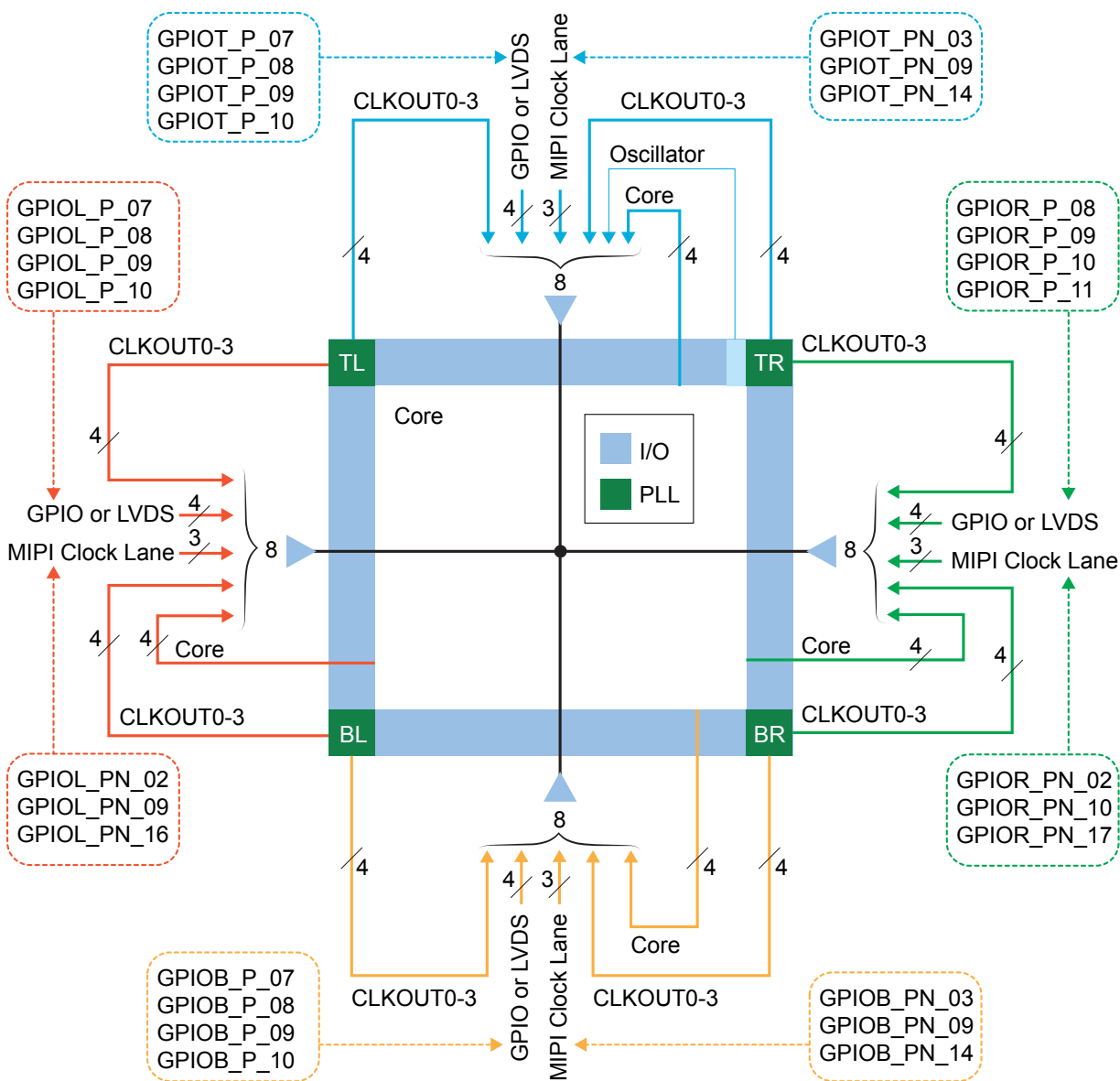

Numerous clock sources feed the global network. These signals are multiplexed together with static and dynamic clock multiplexers.

The dynamic multiplexers are configurable by the user at run-time. You can choose which clock source drives which input to the dynamic multiplexer. When you enable the dynamic multiplexer, you specify a select bus to choose which clock source is active.

When dynamically switching between the clock inputs of a dynamic multiplexer, both the currently active input and the input you intend to switch to must have toggling clocks during the switching period. Additionally, upon configuration completion and when the device transitions into user mode, input 0 of the dynamic multiplexer becomes the default active input. Therefore, you must feed a toggling clock to input 0 before switching to other inputs.

The following figures show the resources that drive each multiplexer.

Figure 8: Clock Sources that Drive the Multiplexers: Top

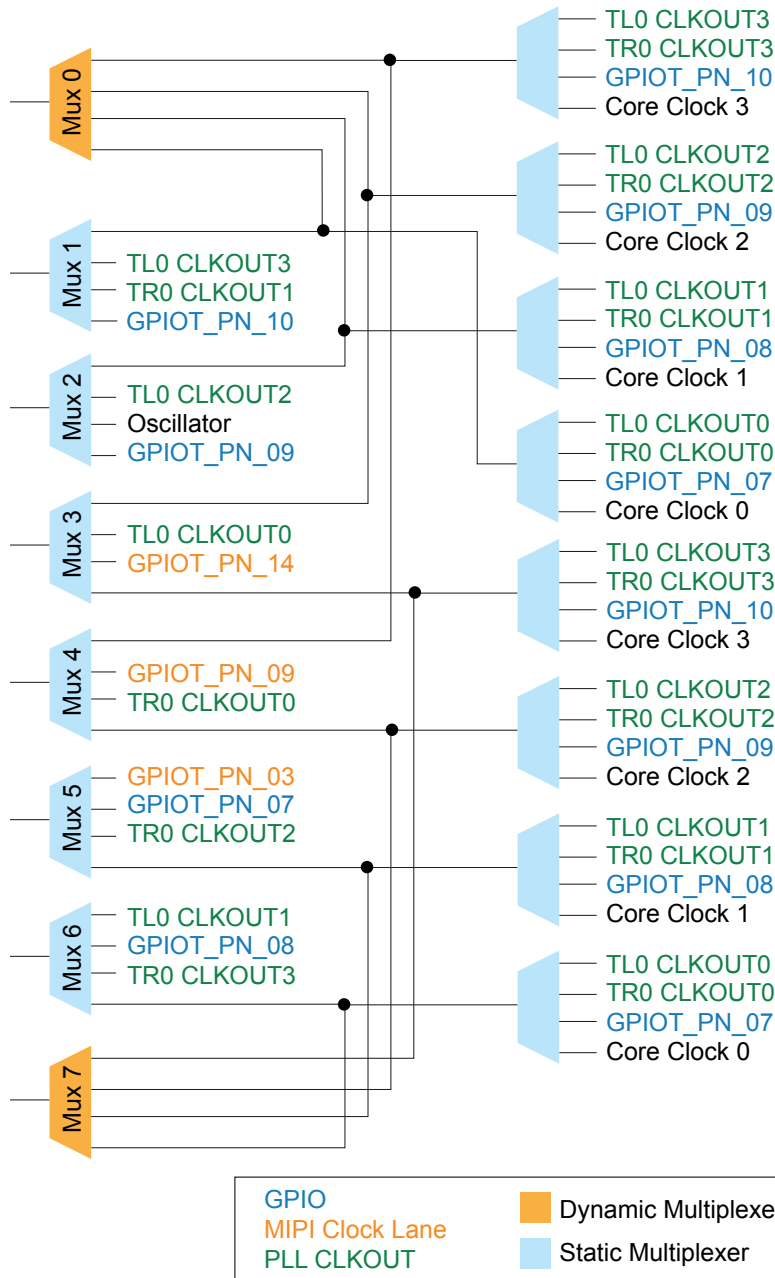

Figure 9: Clock Sources that Drive the Multiplexers:
Bottom

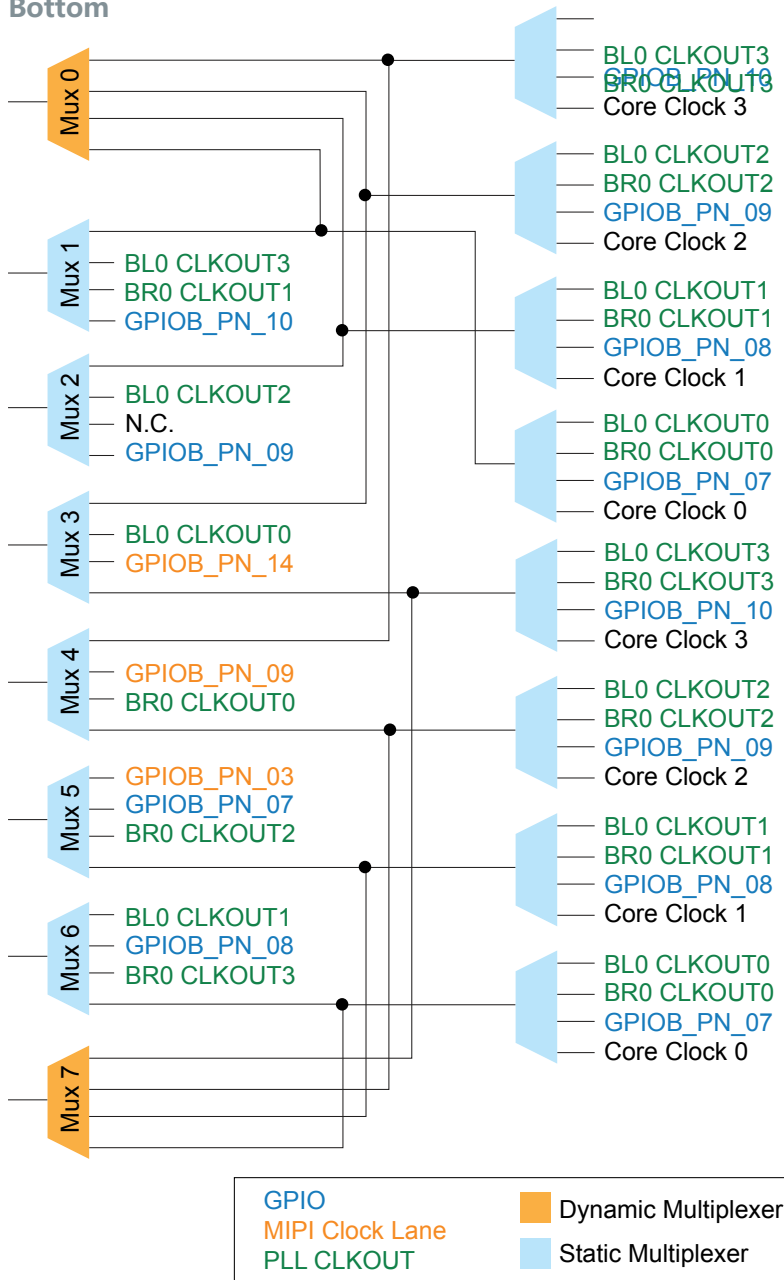

Figure 10: Clock Sources that Drive the Multiplexers:
Left

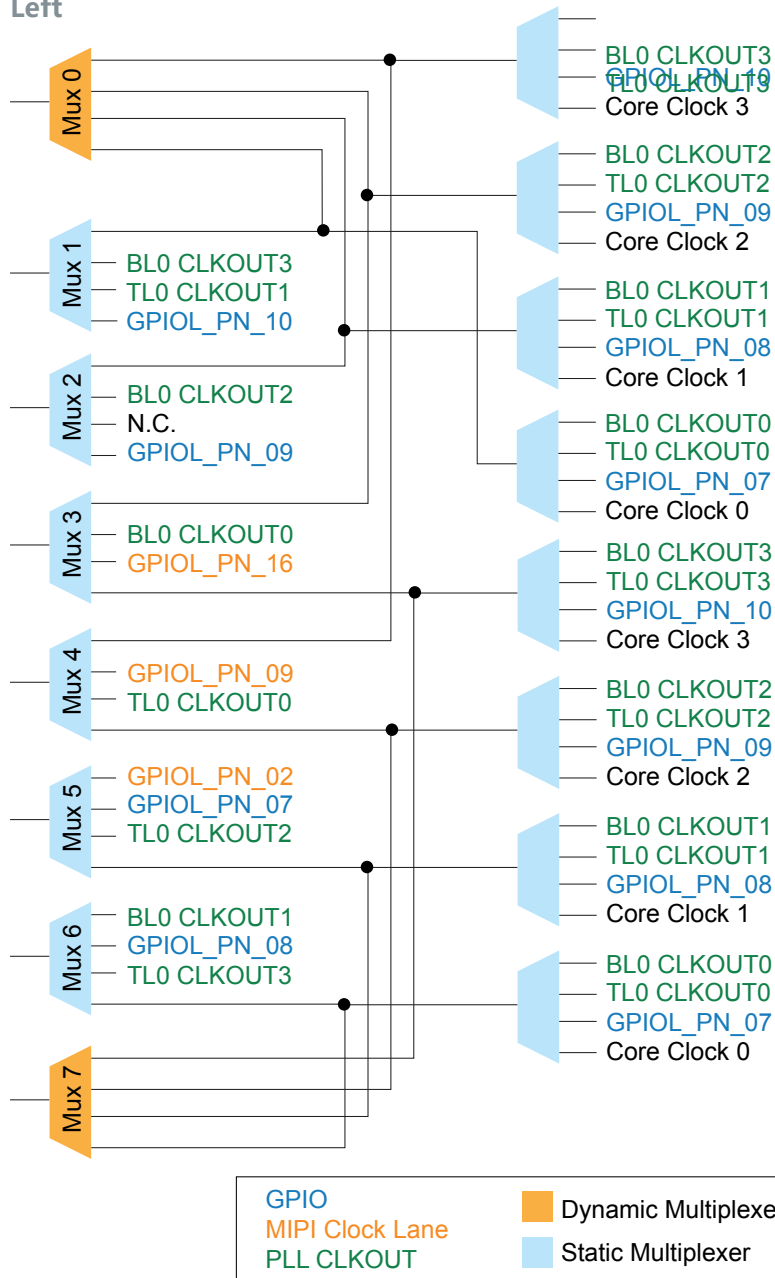
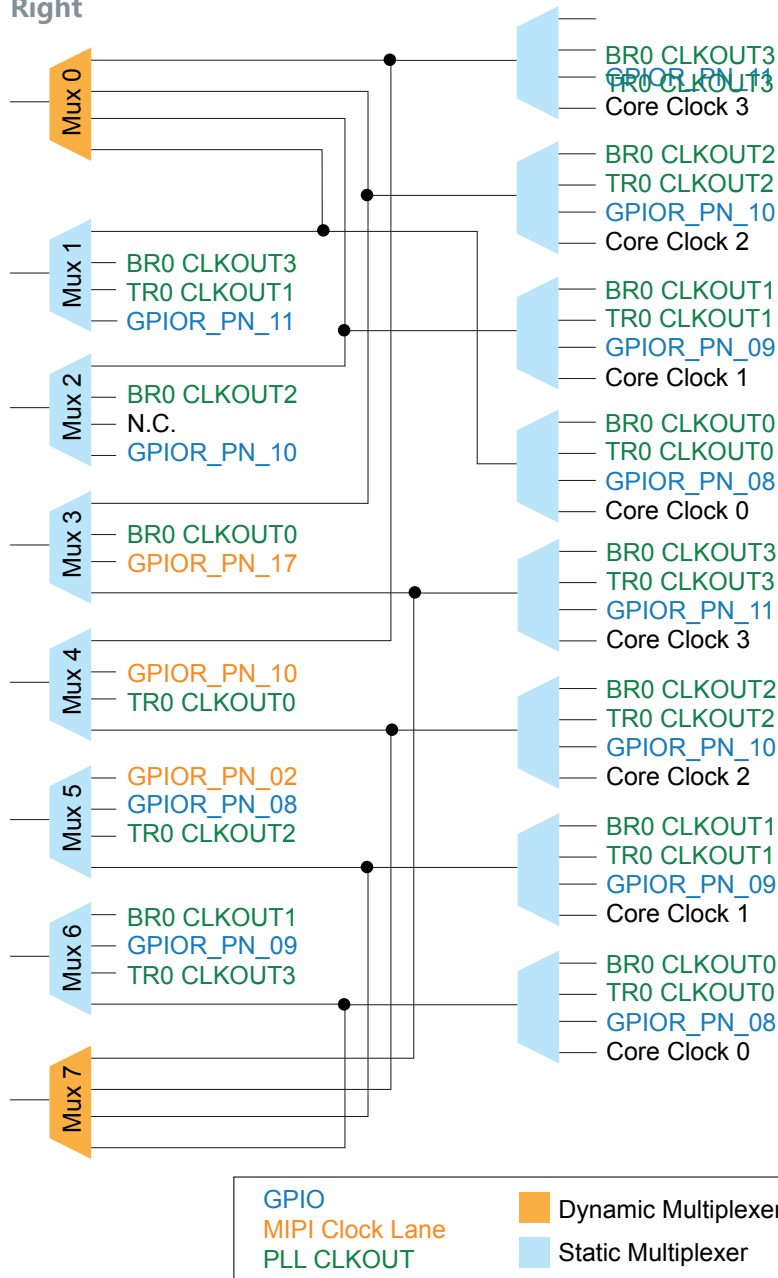

Figure 11: Clock Sources that Drive the Multiplexers:
Right



Driving the Regional Network

The following figure shows the regional network clock sources graphically.
The PLL CLKOUT4 can only connect to the top (or bottom) interface.

Figure 12: Clock Sources that Drive the Regional Network

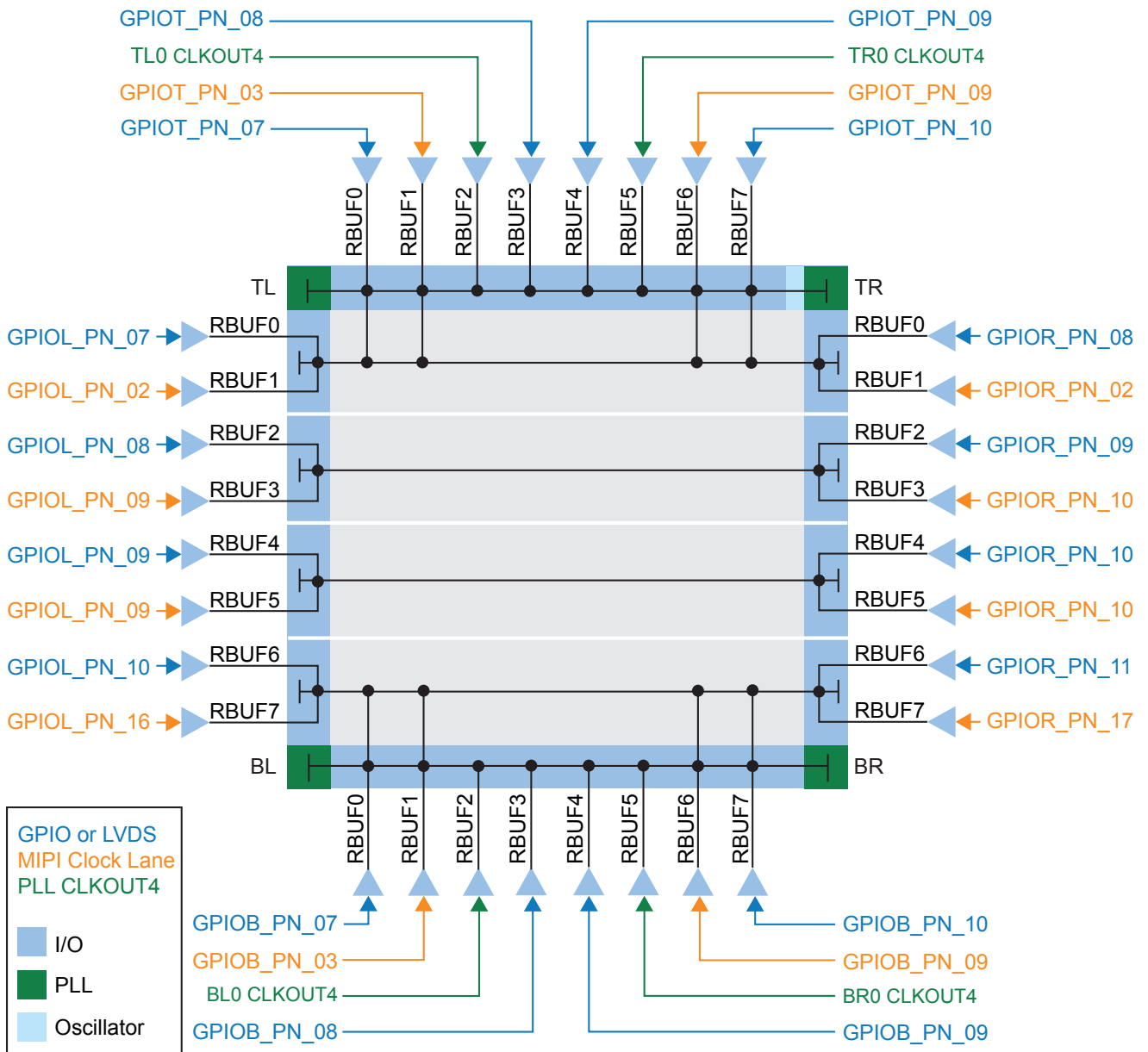

Driving the Local Network

As described previously, the FPGA has horizontal clock regions. The top and bottom regions are **only** for the top and bottom interfaces. The other regions are for the core logic (XLR cells, DSP Blocks, and RAM) and the interfaces on the sides.

Local Network for Core Logic

As shown in the following figure, the regions that contain the core logic are 80 XLR cells tall, and the local network connects an area that is 40 XLR cells tall. Additionally, each column has its own local network. For example, in the first column, XLR cells 1 - 40 are in the same local network and XLR cells 41 - 80 are in another local network. DSP Blocks and RAM also have their own local networks. This pattern of block/local network is repeated for each column in the die.

Figure 13: Clock Sources for Logic, DSP Blocks, and RAM

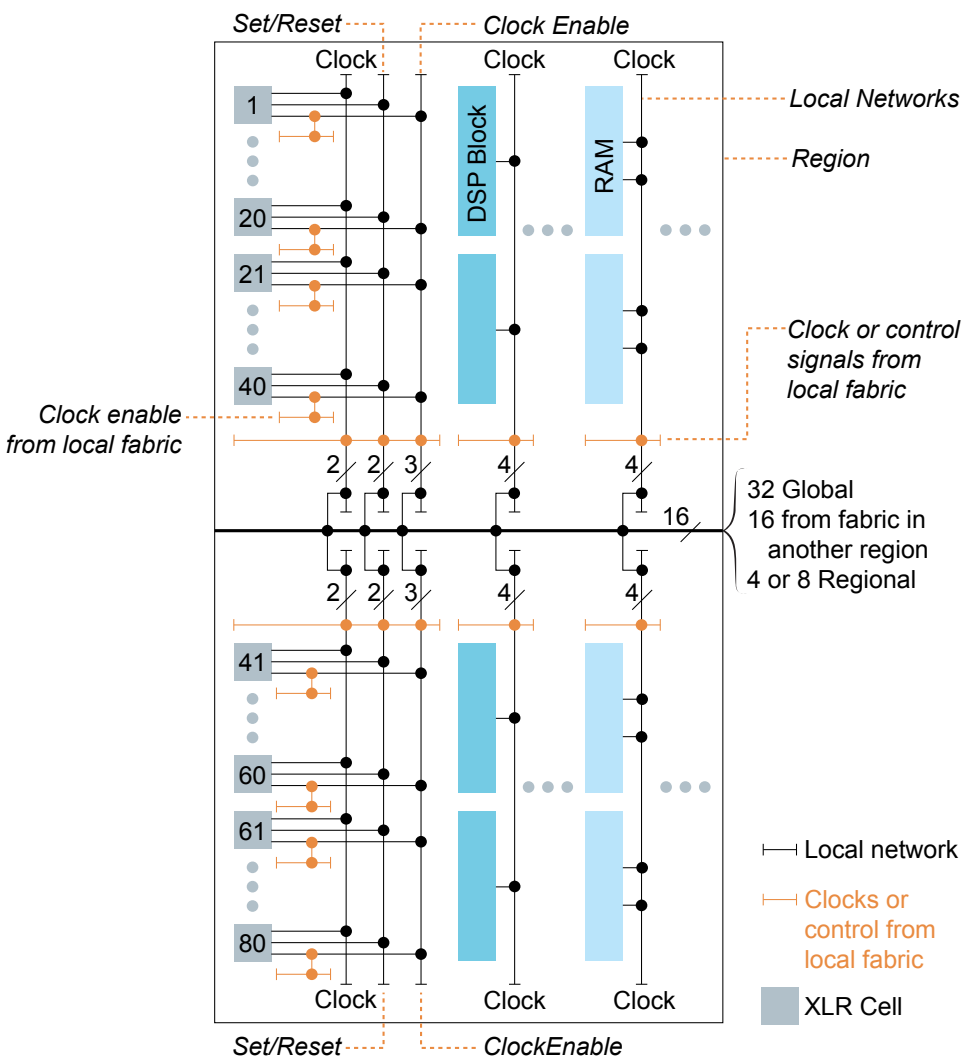

There are 16 signals that can feed the local networks. These signals can come from several sources:

- The global network (32 possible signals)
- The core fabric in another region (16 possible signals)
- The regional network (4 or 8 possible signals):
 - For the top and bottom regions 8 signals can come from the regional network.
 - For the other regions, 4 signals can come from the regional network. (Refer back to Page9 **Clock and Control Network**.)

Additionally, the local fabric can generate clock and control signals for the local network. The fabric can also drive the clock enable for the XLR cell directly, allowing each XLR cell to have a unique clock enable.

Local Network for Interface Regions

The following figure shows the local clock networks for the interface blocks. There are a limited number of unique clocks per local clock region.

- The top and bottom regions can each support up to 16 unique clock signals; 14 from the global network and 2 from the fabric.
- The left and right regions can each support up to 4 unique clock signals. Up to 2 can come from the routing fabric, the rest come from the global or regional buffers. These regions are the same height as the core local regions (that is, 40 rows).

Figure 14: Clock Sources that Drive the Interfaces



Note:

1. 14 signals come from the global network; 2 come from the routing fabric.
2. Up to 2 signals can come from the routing fabric. The rest come from the regional/global buffer.

Device Interface Functional Description

The device interface wraps the core and routes signals between the core and the device I/O pads through a signal interface. Because they use the flexible Quantum[®] architecture, devices in the TJ-Series family support a variety of interfaces to meet the needs of different applications.



Learn more: The following sections describe the available device interface features in Ti60 FPGAs. Refer to the Ti-series Interfaces User Guide for details on the Efinity[®] Interface Designer settings.

Interface Block Connectivity

The FPGA core fabric connects to the interface blocks through a signal interface. The interface blocks then connect to the package pins. The core connects to the interface blocks using three types of signals:

- Input—Input data or clock to the FPGA core
- Output—Output from the FPGA core
- Clock output—Clock signal from the core clock tree

Figure 15: Interface Block and Core Connectivity

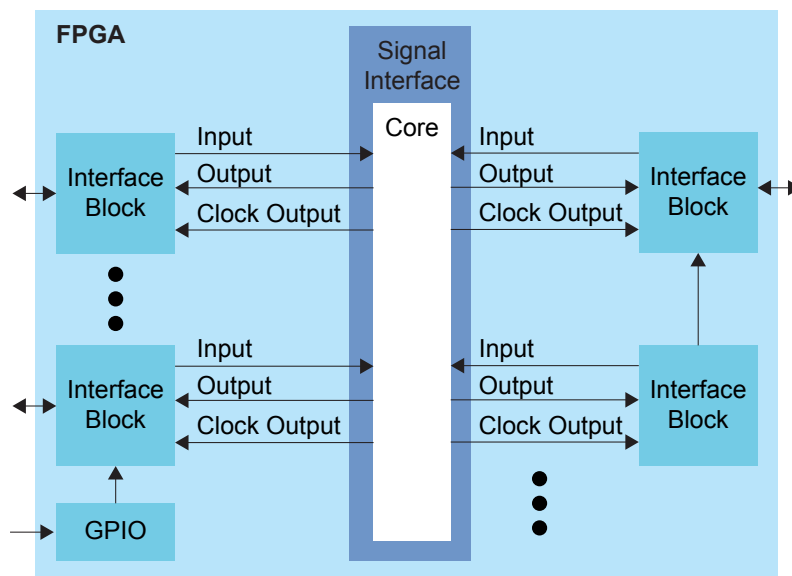

GPIO blocks are a special case because they can operate in several modes. For example, in alternate mode the GPIO signal can bypass the signal interface and directly feed another interface block. So a GPIO configured as an alternate input can be used as a PLL reference clock without going through the signal interface to the core.

When designing for TJ-Series FPGAs, you create an RTL design for the core and also configure the interface blocks. From the perspective of the core, outputs from the core are inputs to the interface block and inputs to the core are outputs from the interface block.

The Efinity netlist always shows signals from the perspective of the core, so some signals do not appear in the netlist:

- GPIO used as reference clocks are not present in the RTL design, they are only visible in the interface block configuration of the Efinity[®] Interface Designer.
- The FPGA clock tree is connected to the interface blocks directly. Therefore, clock outputs from the core to the interface are not present in the RTL design, they are

only part of the interface configuration (this includes GPIO configured as output clocks).

The following sections describe the different types of interface blocks. Signals and block diagrams are shown from the perspective of the interface, not the core.

GPIO

The Ti60 FPGA supports two types of GPIO:

- High-voltage I/O (HVIO)—Simple I/O blocks that can support single-ended I/O standards.
- High-speed I/O (HSIO)—Complex I/O blocks that can support single-ended and differential I/O functionality.

The I/O logic comprises three register types:

- Input—Capture interface signals from the I/O before being transferred to the core logic
- Output—Register signals from the core logic before being transferred to the I/O buffers
- Output enable—Enable and disable the I/O buffers when I/O used as output

The HVIO supports the following I/O standards.

Table 5: HVIO Supported Standards

Standard	VCCIO33 (V)	When Configured As
LVTTTL 3.3 V	3.3	GPIO
LVTTTL 3.0 V	3.0	GPIO
LVC MOS 3.3 V	3.3	GPIO
LVC MOS 3.0 V	3.0	GPIO
LVC MOS 2.5 V	2.5	GPIO
LVC MOS 1.8 V	1.8	GPIO



Important: Elitestek recommends that you limit the number of 3.0/3.3 V HVIO as bidirectional or output to 6 per bank to avoid switching noise. The Efinity® software issues a warning if you exceed the recommended limit.

The HSIO supports the following I/O standards.

Table 6: HSIO Supported I/O Standards

Standard	VCCIO (V)		VCCAUX (V)	VREF (V)	When Configured As
	TX	RX			
LVC MOS 1.8 V	1.8	1.8	1.8	–	GPIO
LVC MOS 1.5 V	1.5	1.5	1.8	–	GPIO
LVC MOS 1.2 V	1.2	1.2	1.8	–	GPIO
HSTL/Differential HSTL 1.8 V SSTL/Differential SSTL 1.8 V	1.8	1.8	1.8	0.9	GPIO
HSTL/Differential HSTL 1.5 V SSTL/Differential SSTL 1.5 V	1.5	1.5, 1.8 ⁽⁴⁾	1.8	0.75	GPIO
SSTL/Differential SSTL 1.35 V	1.35	1.35, 1.5, 1.8 ⁽⁴⁾	1.8	0.675	GPIO
HSTL/Differential HSTL 1.2 V SSTL/Differential SSTL 1.2 V	1.2	1.2, 1.35, 1.5, 1.8 ⁽⁴⁾	1.8	0.6	GPIO
LVDS/RSDS/mini-LVDS	1.8	1.5, 1.8 ⁽⁴⁾	1.8	–	LVDS

⁽⁴⁾ To prevent pin leakage, you must ensure that the voltage at the pin does not exceed VCCIO.

Standard	VCCIO (V)		VCCAUX (V)	VREF (V)	When Configured As
	TX	RX			
Sub-LVDS	1.8	1.5, 1.8 ⁽⁴⁾	1.8	–	LVDS
MIPI	1.2	1.2	1.8	–	MIPI Lane
SLVS	1.2	1.2	1.8	–	LVDS

The differential receivers are powered by VCCAUX, which gives you the flexibility to choose the VCCIO you want to use. However, you must comply to the requirements stated in the previous table.

Features for HVIO and HSIO Configured as GPIO

The following table describes the features supported by HVIO and HSIO configured as GPIO.

Table 7: Features for HVIO and HSIO Configured as GPIO

Feature	HVIO	HSIO Configured as GPIO
Double-data I/O (DDIO)	✓	✓
Dynamic pull-up	–	✓
Pull-up/Pull-down	✓	✓
Slew-Rate Control	–	✓
Variable Drive Strength	✓	✓
Schmitt Trigger	✓	✓
1:4 Serializer/Deserializer (Full rate mode only)	–	✓
Programmable Bus Hold	–	✓
Static Programmable Delay Chains	✓	✓
Dynamic Programmable Delay Chains	–	✓

Table 8: GPIO Modes

GPIO Mode	Description
Input	Only the input path is enabled; optionally registered. If registered, the input path uses the input clock to control the registers (positively or negatively triggered). Select the alternate input path to drive the alternate function of the GPIO. The alternate path cannot be registered. In DDIO mode, two registers sample the data on the positive and negative edges of the input clock, creating two data streams.
Output	Only the output path is enabled; optionally registered. If registered, the output path uses the output clock to control the registers (positively or negatively triggered). The output register can be inverted. In DDIO mode, two registers capture the data on the positive and negative edges of the output clock, multiplexing them into one data stream.
Bidirectional	The input, output, and OE paths are enabled; optionally registered. If registered, the input clock controls the input register, the output clock controls the output and OE registers. All registers can be positively or negatively triggered. Additionally, the input and output paths can be registered independently. The output register can be inverted.
Clock output	Clock output path is enabled.

During configuration, all GPIO pins are configured in weak pull-up mode.

During user mode, unused GPIO pins are tristated and configured in weak pull-up mode. You can change the default mode to weak pull-down in the Interface Designer.

Double-Data I/O

Ti60 FPGAs support double data I/O (DDIO) on input and output registers. In this mode, the DDIO register captures data on both positive and negative clock edges. The core receives 2 bit wide data from the interface.

In normal mode, the interface receives or sends data directly to or from the core on the positive and negative clock edges. In resync and pipeline mode, the interface resynchronizes the data to pass both signals on the positive clock edge only.

Figure 16: DDIO Input Timing Waveform

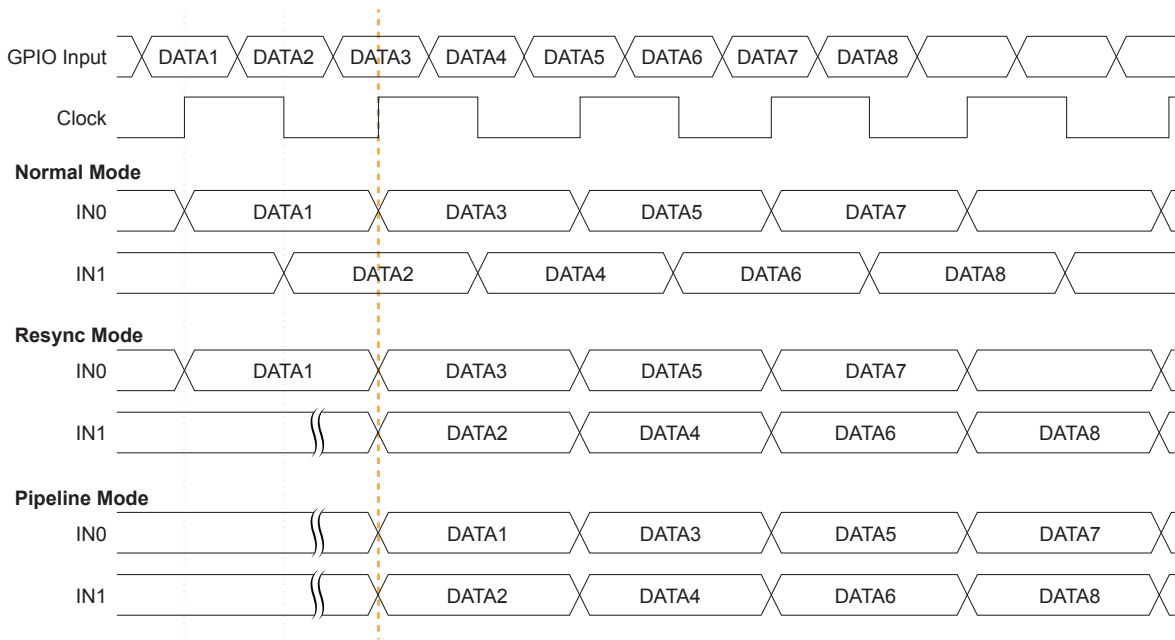

In resync mode, the IN1 data captured on the falling clock edge is delayed one half clock cycle.

In the Interface Designer, IN0 is the HI pin name and IN1 is the LO pin name.

Figure 17: DDIO Output Timing Waveform

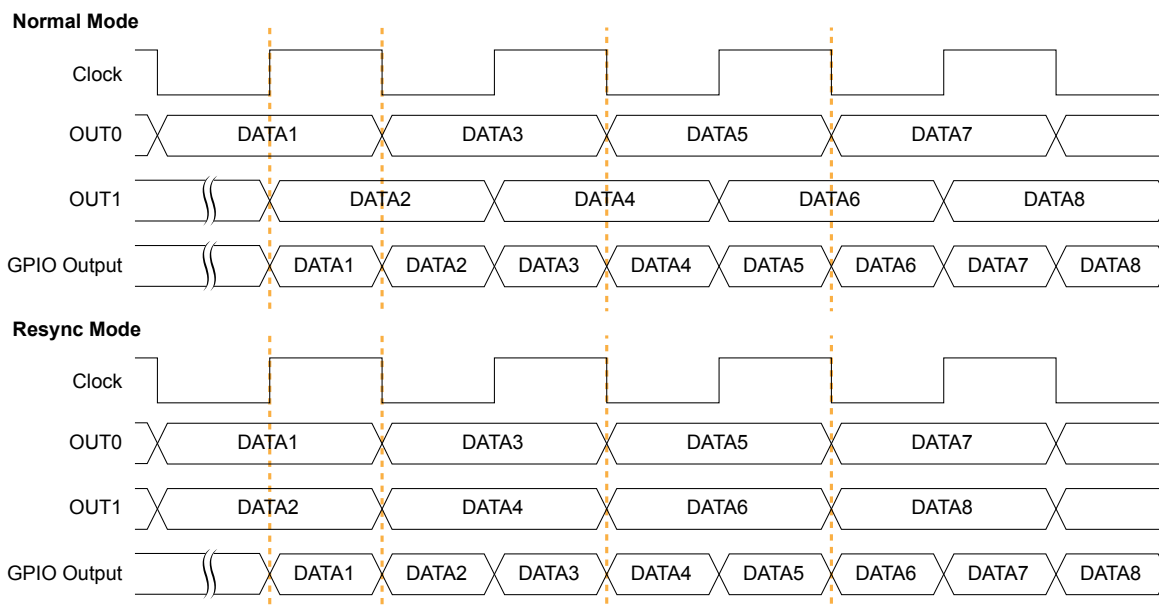

In the Interface Designer, OUT0 is the HI pin name and OUT1 is the LO pin name.

Programmable Delay Chains

The HVIO and HSIO configured as GPIO support programmable delay chain. In some cases you can use static and dynamic delays at the same time.

Table 9: Programmable Delay Support

Delay Type	GPIO Type	Delay Steps	Notes
Static	HVIO	16	Available on input and output paths.
	Single-Ended HSIO	16	Available on input and output paths.
	Differential RX HSIO	64	Cannot use static and dynamic delay at the same time. Only available on P input of the HSIO pair.
	Differential TX HSIO	64	
Dynamic	Single-Ended HSIO	64	Only available on input path.
	Differential RX HSIO	64	Only available on P input of the HSIO pair.



Learn more: Refer to the following tables for the delay step size:

Page59 [Table 50: Single-Ended I/O Programmable Delay Chain Step Size: Static](#)

Page59 [Table 51: Single-Ended I/O Programmable Delay Chain Step Size: Dynamic](#)

Page59 [Table 52: Differential I/O Programmable Delay Chain Step Size: Static and Dynamic](#)

HVIO

The HVIOs are grouped into banks. Each bank has its own VCCIO33 that sets the bank voltage for the I/O standard. Each HVIO consists of I/O logic and an I/O buffer. I/O logic connects the core logic to the I/O buffers. I/O buffers are located at the periphery of the device.

Figure 18: HVIO Interface Block

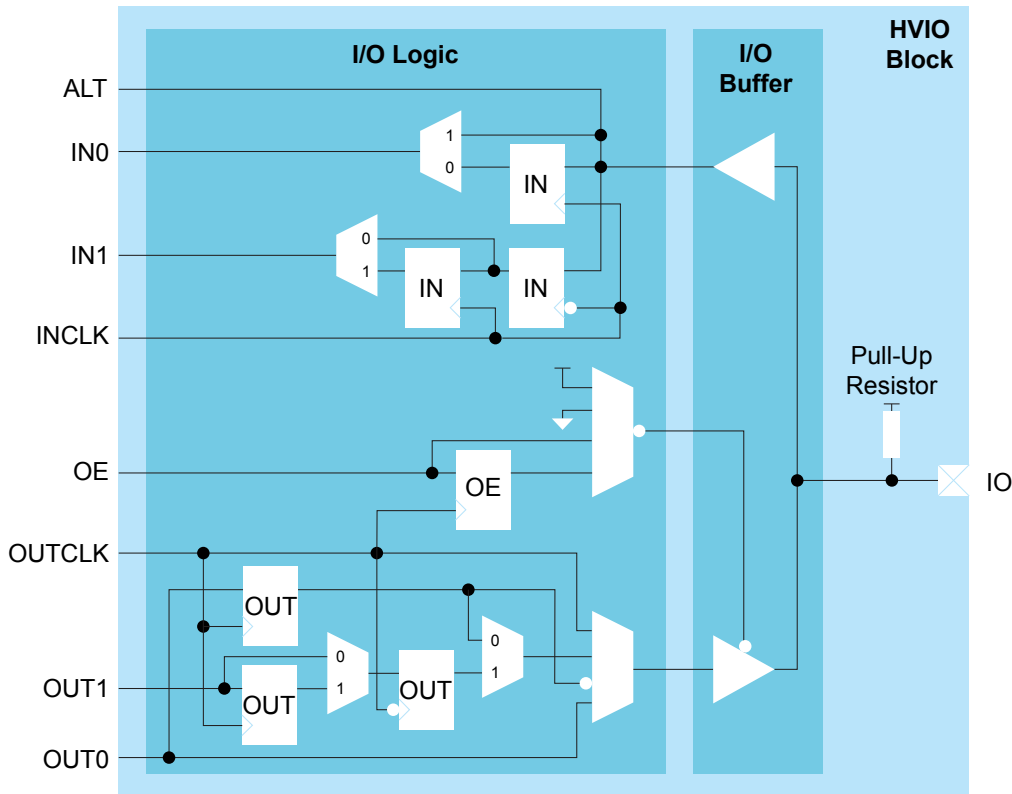

Table 10: HVIO Signals (Interface to FPGA Fabric)

Signal	Direction	Description
IN[1:0]	Output	Input data from the HVIO pad to the core fabric. IN0 is the normal input to the core. In DDIO mode, IN0 is the data captured on the positive clock edge (HI pin name in the Interface Designer) and IN1 is the data captured on the negative clock edge (LO pin name in the Interface Designer).
ALT	Output	Alternative input connection (in the Interface Designer, Register Option is none). HVIO only support pll_clkln as the alternative connection.
OUT[1:0]	Input	Output data to HVIO pad from the core fabric. OUT0 is the normal output from the core. In DDIO mode, OUT0 is the data captured on the positive clock edge (HI pin name in the Interface Designer) and OUT1 is the data captured on the negative clock edge (LO pin name in the Interface Designer).
OE	Input	Output enable from core fabric to the I/O block. Can be registered.
OUTCLK	Input	Core clock that controls the output and OE registers. This clock is not visible in the user netlist.
INCLK	Input	Core clock that controls the input registers. This clock is not visible in the user netlist.

Table 11: HVIO Pads

Signal	Direction	Description
IO	Bidirectional	HVIO pad.

HSIO

Each HSIO block uses a pair of I/O pins as one of the following:

- Single-ended HSIO—Two single-ended I/O pins (LVCMOS, SSTL, HSTL)

Figure: Differential HSIO—One differential I/O pins:

- Differential SSTL and HSTL
- LVDS—Receiver (RX), transmitter (TX), or bidirectional (RX/TX)
- MIPI lane I/O—Receiver (RX) or transmitter (TX)

Figure 19: HSIO Buffer Block Diagram

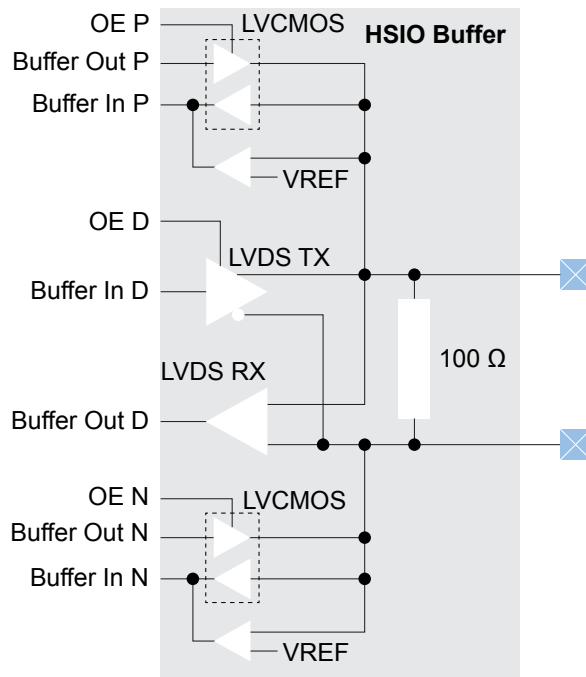

Important: When you are using an HSIO pin as a GPIO, make sure to leave at least 1 pair of unassigned HSIO pins between any GPIO and LVDS or MIPI lane pins. This rule applies for pins on each side of the device (top, bottom, left, right). This separation reduces noise. The Efinity software issues an error if you do not leave this separation.

HSIO Configured as GPIO

You can configure each HSIO block as two GPIO (single-ended) or one GPIO (differential).

Figure 20: I/O Interface Block

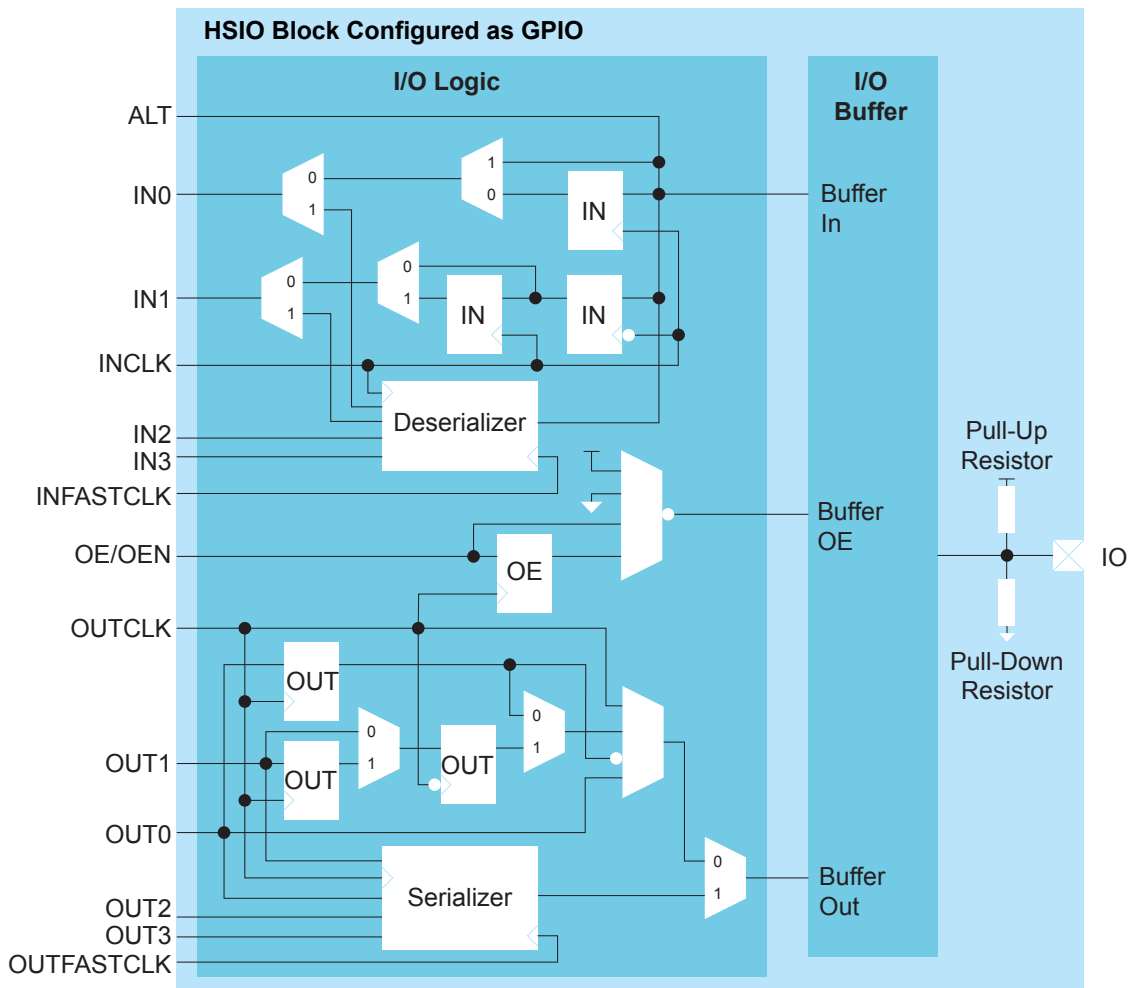

Table 12: HSIO Block Configured as GPIO Signals (Interface to FPGA Fabric)

Signal	Direction	Description
IN[3:0]	Output	Input data from the pad to the core fabric. IN0 is the normal input to the core. In DDIO mode, IN0 is the data captured on the positive clock edge (HI pin name in the Interface Designer) and IN1 is the data captured on the negative clock edge (LO pin name in the Interface Designer). When using the deserializer, the first bit is on IN0 and the last bit is on IN3.
ALT	Output	Alternative input connection for GCLK, PLL_CLKIN, RCLK, PLL_EXTFB, and VREF. (In the Interface Designer, Register Option is none).
OUT[3:0]	Input	Output data to GPIO pad from the core fabric. OUT0 is the normal output from the core. In DDIO mode, OUT0 is the data captured on the positive clock edge (HI pin name in the Interface Designer) and OUT1 is the data captured on the negative clock edge (LO pin name in the Interface Designer). When using the serializer, the first bit is on OUT0 and the last bit is on OUT3.
OE/OEN	Input	Output enable from core fabric to the I/O block. Can be registered. OEN is used in differential mode. Drive it with the same signal as OE.
DLY_ENA	Input	(Optional) Enable the dynamic delay control.
DLY_INC	Input	(Optional) Dynamic delay control. When DLY_ENA = 1, 1: Increments 0: Decrements The updated delay count takes effect approximately 5 ns after the rising edge of the clock.
DLY_RST	Input	(Optional) Reset the delay counter.
OUTCLK	Input	Core clock that controls the output and OE registers. This clock is not visible in the user netlist.
OUTFASTCLK	Input	Core clock that controls the output serializer.
INCLK	Input	Core clock that controls the input registers. This clock is not visible in the user netlist.
INFASTCLK	Input	Core clock that controls the input serializer.

Table 13: GPIO Pads

Signal	Direction	Description
IO (P and N)	Bidirectional	GPIO pad.

The signal path from the pad through the I/O buffer changes depending on the I/O standard you are using. The following figures show the paths for the supported standards. The blue highlight indicates the path.

Figure 21: I/O Buffer Path for LVCMOS

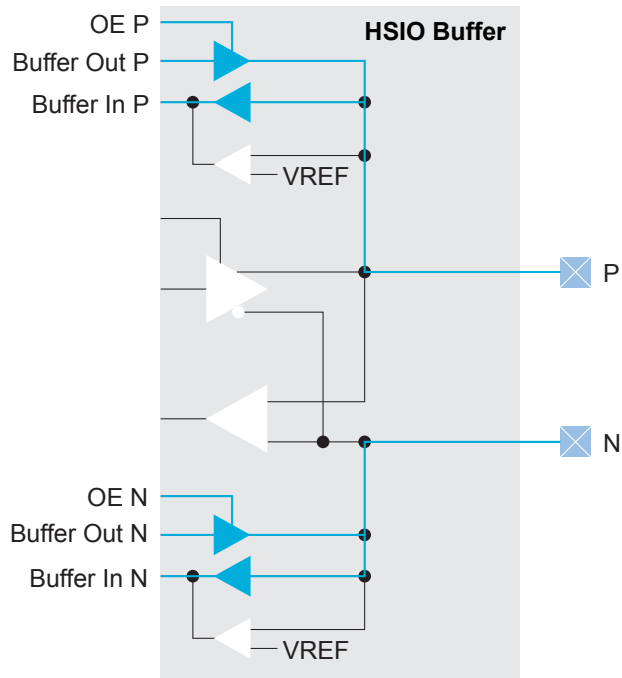

When using an HSIO with the HSTL or SSTL I/O standards, you must configure an I/O pad of the standard's input path as a V_{REF} pin. There is one programmable V_{REF} per I/O bank.



Important: When configuring an I/O pad of the standard's input path as a V_{REF} pin, you must use the V_{REF} from the same physical I/O bank even when the I/O banks are merged to share a common VCCIO pin.

Figure 22: I/O Buffer Path for HSTL and SSTL

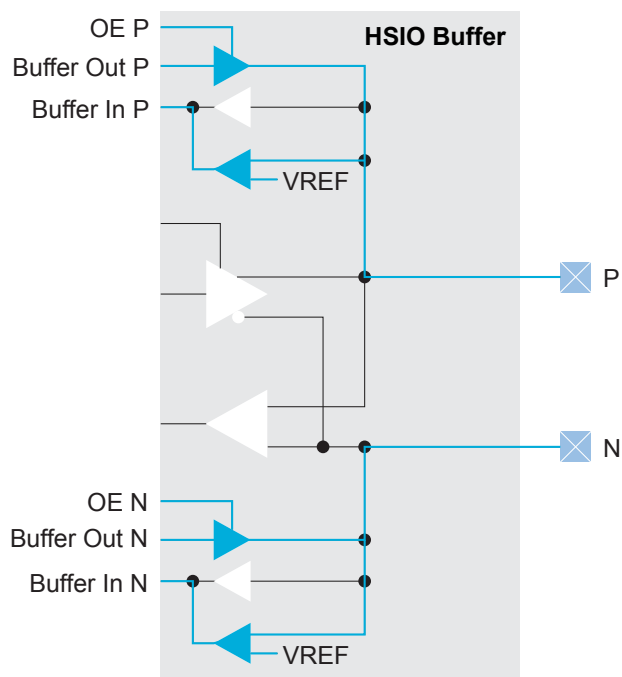

When using an HSIO with the differential HSTL or differential SSTL standard, you must use both GPIO resources in the HSIO. You use the core interface pins associated with the P resource.

Figure 23: I/O Buffer Path for Differential HSTL and SSTL

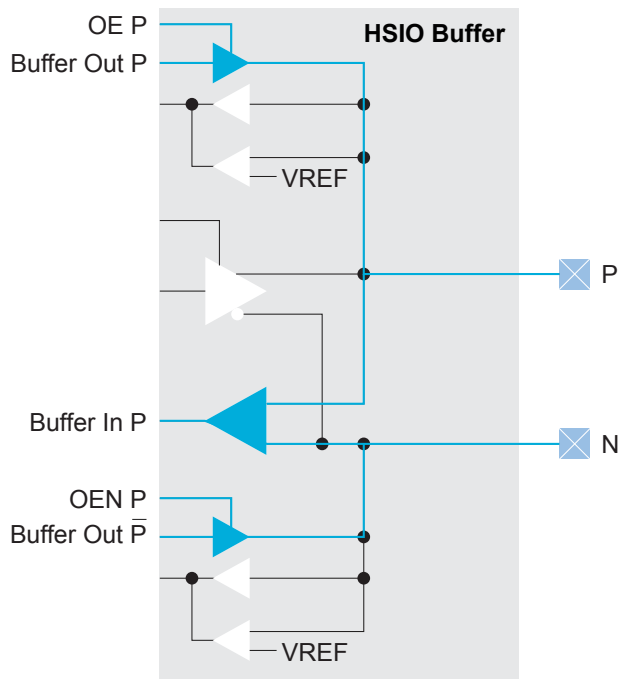

HSIO Configured as LVDS

You can configure each HSIO block in RX, TX, or bidirectional LVDS mode. As LVDS, the HSIO has these features:

- Programmable V_{OD} , depending on the I/O standard used.
- Programmable pre-emphasis.
- Up to 1.5 Gbps.
- Programmable $100\ \Omega$ termination to save power (you can enable or disable it at runtime).
- LVDS input enable to dynamically enable/disable the LVDS input.
- Support for full rate or half rate serialization.
- Up to 10-bit serialization to support protocols such as 8b10b encoding.
- Programmable delay chains.
- Optional 8-word FIFO for crossing from the parallel (slow) clock to the user's core clock to help close timing (RX only).
- Dynamic phase alignment (DPA) that automatically eliminates skew for clock to data channels and data to data channels by adjusting a delay chain setting so that data is sampled at the center of the bit period. The DPA supports full-rate serialization mode only.

Table 14: Full and Half Rate Serialization

Mode	Description	Example
Full rate clock	In full rate mode, the fast clock runs at the same frequency as the data and captures data on the positive clock edge.	Data rate: 800 Mbps Serialization/Deserialization factor: 8 Slow clock frequency: 100 Mhz (800 Mbps / 8) Fast clock frequency: 800 Mhz
Half rate clock	In half rate mode, the fast clock runs at half the speed of the data and captures data on both clock edges.	Data rate: 800 Mbps Serialization / Deserialization factor: 8 Slow clock frequency: 100 Mhz (800 Mbps / 8) Fast clock frequency: 400 Mhz (800 / 2)

You use a PLL to generate the serial (fast) and parallel (slow) clocks for the LVDS pins. The slow clock runs at the data rate divided by the serialization factor.

Ti60 FPGAs do not have a dedicated LVDS clock tree; therefore, the fast and slow clocks must use global or regional clocks to feed the LVDS primitives.

LVDS RX

You can configure an HSIO block as one LVDS RX signal.

Figure 24: LVDS RX Interface Block Diagram

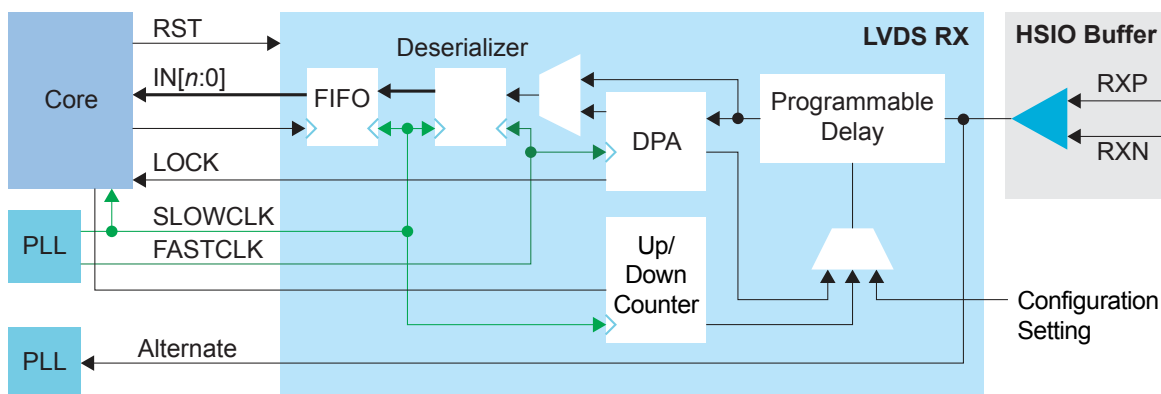
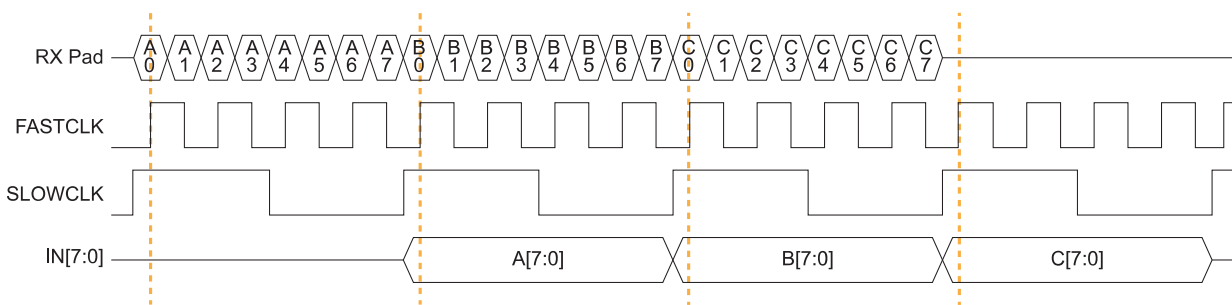

Table 15: LVDS RX Signals (Interface to FPGA Fabric)

Signal	Direction	Clock Domain	Description
IN[9:0]	Output	SLOWCLK	Parallel input data to the core. The width is programmable.
ALT	Output		Alternate input, only available for an LVDS RX resource in bypass mode (deserialization width is 1; alternate connection type). Alternate connections are PLL_CLKIN, PLL_EXTFB, GCLK, and RCLK.
LOCK	Output		(Optional) When DPA is enabled, this signal indicates that the DPA has achieved training lock and data can be passed.
FIFO_EMPTY	Output	FIFOCLK	(Optional) When FIFO is enabled, this signal indicates that the FIFO is empty.
SLOWCLK	Input	–	Parallel (slow) clock.
FASTCLK	Input	–	Serial (fast) clock.
FIFOCLK	Input	–	(Optional) Core clock to read from the FIFO.
FIFO_RD	Input	FIFOCLK	(Optional) Enables FIFO to read.
RST	Input	FIFOCLK SLOWCLK	(Optional) Asynchronous. Resets the FIFO and serializer. If the FIFO is enabled, it is relative to FIFOCLK; otherwise it is relative to SLOWCLK.
ENA	Input	–	Dynamically enable or disable the LVDS input buffer. Can save power when disabled. 1: Enabled 0: Disabled
TERM	Input	–	Enables or disables termination in dynamic termination mode. 1: Enabled 0: Disabled
DLY_ENA	Input	SLOWCLK	(Optional) Enable the dynamic delay control or the DPA circuit, depending on the LVDS RX delay settings.
DLY_INC	Input	SLOWCLK	(Optional) Dynamic delay control. Cannot be used with DPA enabled. When DLY_ENA is 1: 1: Increments 0: Decrements
DLY_RST	Input	SLOWCLK	(Optional) Reset the delay counter or the DPA circuit, depending on the LVDS RX delay settings.

The following waveform shows the relationship between the fast clock, slow clock, RX data coming in from the pad, and byte-aligned data to the core.

Figure 25: LVDS RX Timing Example Serialization Width of 8 (Half Rate)



IN is byte-aligned data passed to the core on the rising edge of SLOWCLK.



Note: For LVDS RX interfaces with multiple LVDS RX lanes and an LVDS RX clock input, use the LVDS RX blocks from the same side of the FPGA to minimize skew between data lanes and RX clock input.

LVDS TX

You can configure an HSIO block as one LVDS TX signal. LVDS TX can be used in the serial data output mode or reference clock output mode.

Figure 26: LVDS TX Interface Block Diagram

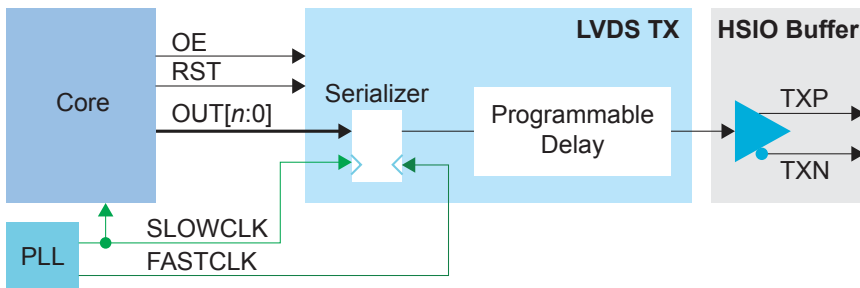
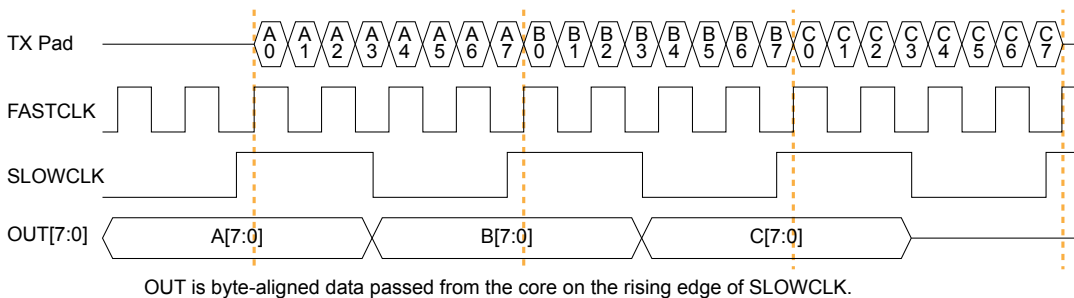

Table 16: LVDS TX Signals (Interface to FPGA Fabric)

Signal	Direction	Clock Domain	Description
OUT[9:0]	Input	SLOWCLK	Parallel output data from the core. The width is programmable.
SLOWCLK	Input	-	Parallel (slow) clock.
FASTCLK	Input	-	Serial (fast) clock.
RST	Input	SLOWCLK	(Optional) Resets the serializer.
OE	Input	-	(Optional) Output enable signal.

The following waveform shows the relationship between the fast clock, slow clock, TX data going to the pad, and byte-aligned data from the core.

Figure 27: LVDS Timing Example Serialization Width of 8 (Half Rate)



Note: For LVDS TX interfaces with multiple LVDS TX lanes and an LVDS TX reference clock output, use the LVDS TX blocks from the same side of the FPGA to minimize skew between data lanes and TX reference clock output.

LVDS Bidirectional

You can configure an HSIO block as one LVDS bidirectional signal. You must use the same serialization for the RX and TX.

Figure 28: LVDS Bidirectional Interface Block Diagram

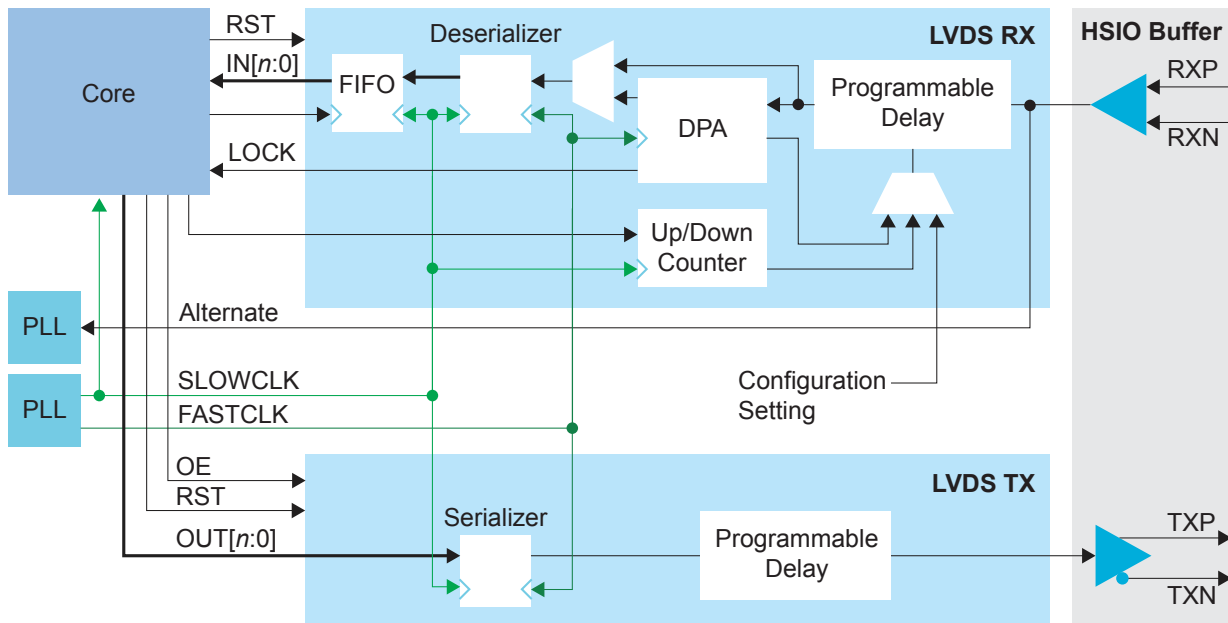

Table 17: LVDS Bidirectional Signals (Interface to FPGA Fabric)

Signal	Direction	Clock Domain	Description
IN[9:0]	Output	SLOWCLK	Parallel input data to the core. The width is programmable.
LOCK	Output	–	(Optional) When DPA is enabled, this signal indicates that the DPA has achieved training lock and data can be passed.
FIFO_EMPTY	Output	FIFOCLK	(Optional) When the FIFO is enabled, this signal indicates that the FIFO is empty.
INSLOWCLK	Input	–	Parallel (slow) clock for RX.
INFASTCLK	Input	–	Serial (fast) clock for RX.
FIFOCLK	Input	–	(Optional) Core clock to read from the FIFO.
FIFO_RD	Input	FIFOCLK	(Optional) Enables FIFO to read.
INRST	Input	FIFOCLK SLOWCLK	(Optional) Asynchronous. Resets the FIFO and RX serializer. If the FIFO is enabled, it is relative to FIFOCLK; otherwise it is relative to SLOWCLK.
ENA	Input	–	Dynamically enable or disable the LVDS input buffer. Can save power when disabled. 1: Enabled 0: Disabled
TERM	Input	–	Enables or disables termination in dynamic termination mode. 1: Enabled 0: Disabled
DLY_ENA	Input	SLOWCLK	(Optional) Enable the dynamic delay control or the DPA circuit, depending on the Bidirectional LVDS delay settings.
DLY_INC	Input	SLOWCLK	(Optional) Dynamic delay control. Cannot be used with DPA enabled. When DLY_ENA is 1, 1: Increments 0: Decrements
DLY_RST	Input	SLOWCLK	(Optional) Reset the delay counter or the DPA circuit, depending on the Bidirectional LVDS delay settings.
DBG[5:0]	Output	SLOWCLK	DPA debug pin. Outputs the final delay chain settings when DPA achieved lock.

Signal	Direction	Clock Domain	Description
OUT[9:0]	Input	SLOWCLK	Parallel output data from the core. The width is programmable.
OUTSLOWCLK	Input	–	Parallel (slow) clock for TX.
OUTFASTCLK	Input	–	Serial (fast) clock for TX.
OUTRST	Input	SLOWCLK	(Optional) Resets the TX serializer.
OE	Input	–	Output enable signal.

LVDS Pads

Table 18: LVDS Pads

Signal	Direction	Description
P	Output	Differential pad P.
N	Output	Differential pad N.

HSIO Configured as MIPI Lane

You can configure the HSIO block as a MIPI RX or TX lane. The block supports bidirectional data lane, unidirectional data lane, and unidirectional clock lane which can run at speeds up to 1.5 Gbps. The MIPI lane operates in high-speed (HS) and low-power (LP) modes. In HS mode, the HSIO block transmits or receives data with x8 serializer/deserializer. In LP mode, it transmits or receives data without deserializer/serializer.

The MIPI lane block does not include the MIPI D-PHY core logic. A full MIPI D-PHY solution requires:

- Multiple MIPI RX or TX lanes (at least a clock lane and a data lane)
- Soft MIPI D-PHY IP core programmed into the FPGA fabric

The MIPI D-PHY standard is a point-to-point protocol with one endpoint (TX) responsible for initiating and controlling communication. Often, the standard is unidirectional, but when implementing the MIPI DSI protocol, you can use one TX data lane for LP bidirectional communication.

The protocol is source synchronous with one clock lane and 1, 2, 4, or 8 data lanes. The number of lanes available depends on which package you are using. A dedicated HSIO block is assigned on the RX interface as a clock lane while the clock lane for TX interface can use any of the HSIO block in the group.

MIPI RX Lane

In RX mode, the HS (fast) clock comes in on the MIPI clock lane and is divided down to generate the slow clock. The fast and slow clocks are then passed to neighboring HSIO blocks to be used for the MIPI data lanes.

The data lane fast and slow clocks must be driven by a clock lane in the same MIPI group (dedicated buses drive from the clock lane to the neighboring data lanes).

The MIPI RX function is defined as:

Table 19: MIPI RX Function

MIPI RX Function	Description
RX_DATA _{xy_zz}	MIPI RX Data Lane. You can use any data lanes within the same group to form multiple lanes of MIPI RX channel. x = P or N y = 0 to 7 data lanes (Up to 8 data lanes per channel) zz = I0 to I11 MIPI RX channel (Up to 12 MIPI RX channels)
RX_CLK _{x_zz}	MIPI RX Clock Lane. One clock lane is required for each MIPI RX channel. x = P or N zz = I0 to I11 MIPI RX channel (Up to 12 MIPI RX channels)

Figure 29: MIPI RX Lane Block Diagram

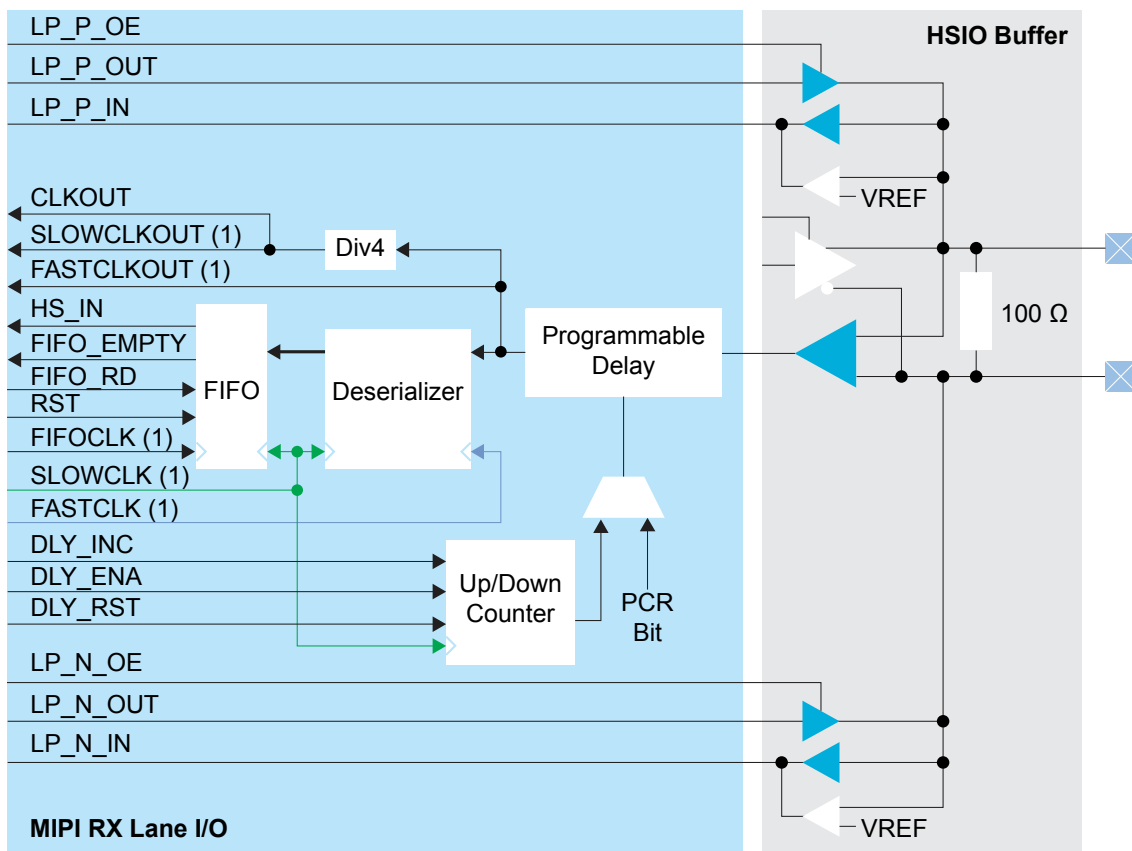

1. These signals are in the primitive, but the software automatically connects them for you.

Table 20: MIPI RX Lane Signals

Interface to MIPI soft CSI/DSI controller with D-PHY in FPGA Fabric

Signal	Direction	Clock Domain	Description
LP_P_OE	Input	–	(Optional) LP output enable signal for P pad.
LP_P_OUT	Input	–	(Optional) LP output data from the core for the P pad. Used if the data lane is reversible.
LP_P_IN	Output	–	LP input data from the P pad.
CLKOUT	Output	–	Divided down parallel (slow) clock from the pads that can drive the core clock tree. Used to drive the core logic implementing the rest of the D-PHY protocol. It should also connect to the FIFOCLK of the data lanes.
SLOWCLKOUT ⁽⁵⁾	Output	–	Divided down parallel (slow) clock from the pads. Can only drive RX DATA lanes.
FASTCLKOUT ⁽⁵⁾	Output	–	Serial (fast) clock from the pads. Can only drive RX DATA lanes.
HS_IN[7:0]	Output	SLOWCLK	High-speed parallel data input.
FIFO_EMPTY	Output	FIFOCLK	(Optional) When the FIFO is enabled, this signal indicates that the FIFO is empty.
FIFO_RD	Input	FIFOCLK	(Optional) Enables FIFO to read.
RST	Input	FIFOCLK SLOWCLK	(Optional) Asynchronous. Resets the FIFO and serializer. If the FIFO is enabled, it is relative to FIFOCLK; otherwise it is relative to SLOWCLK.
FIFOCLK ⁽⁵⁾	Input	–	(Optional) Core clock to read from the FIFO.
SLOWCLK ⁽⁵⁾	Input	–	Parallel (slow) clock.
FASTCLK ⁽⁵⁾	Input	–	Serial (fast) clock.
DLY_INC	Input	SLOWCLK	(Optional) Dynamic delay control. When DLY_ENA is 1, 1: Increments 0: Decrements
DLY_ENA	Input	SLOWCLK	(Optional) Enable the dynamic delay control.
DLY_RST	Input	SLOWCLK	(Optional) Reset the delay counter.
LP_N_OE	Input	–	(Optional) LP output enable signal for N pad.
LP_N_OUT	Input	–	(Optional) LP output data from the core for the N pad. Used if the data lane is reversible.
LP_N_IN	Output	–	LP input data from the N pad.
HS_ENA	Input	–	Dynamically enable the differential input buffer when in high-speed mode.
HS_TERM	Input	–	Dynamically enables input termination high-speed mode.

⁽⁵⁾ These signals are in the primitive, but the software automatically connects them for you.

The clock lane generates the fast clock and slow clock for the RX data lanes within the interface group. It also generates a clock which is divided by 4 that feeds the global network. The following figure shows the clock connections between the clock and data lanes.

Figure 30: Connections for Clock and RX Data Lane in the Same MIPI RX Channel

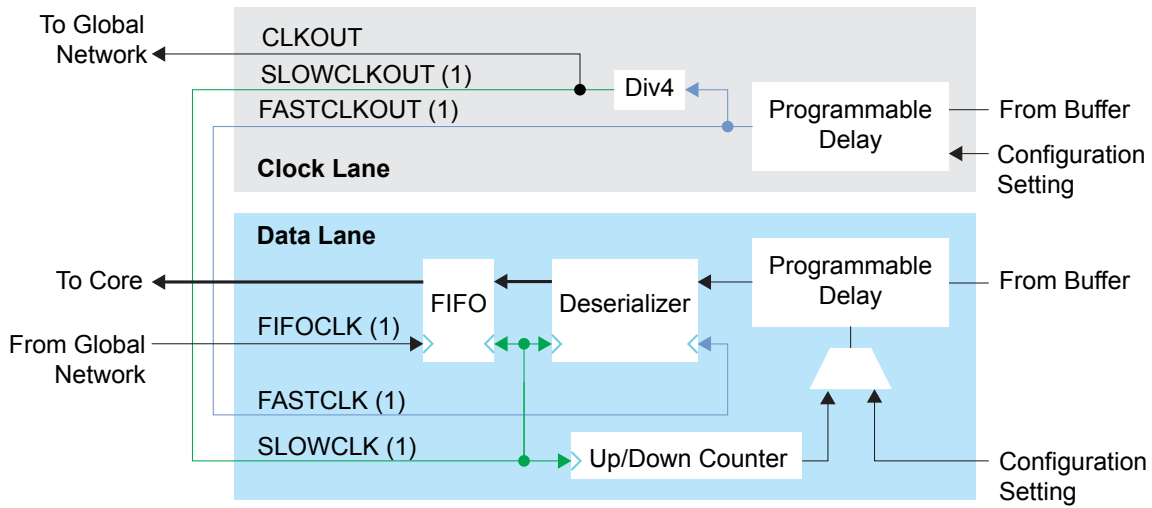

1. The software automatically connects this signal for you.

MIPI TX Lane

In TX mode, a PLL generates the parallel and serial clocks and passes them to the clock and data lanes.

Figure 31: MIPI TX Lane Block Diagram

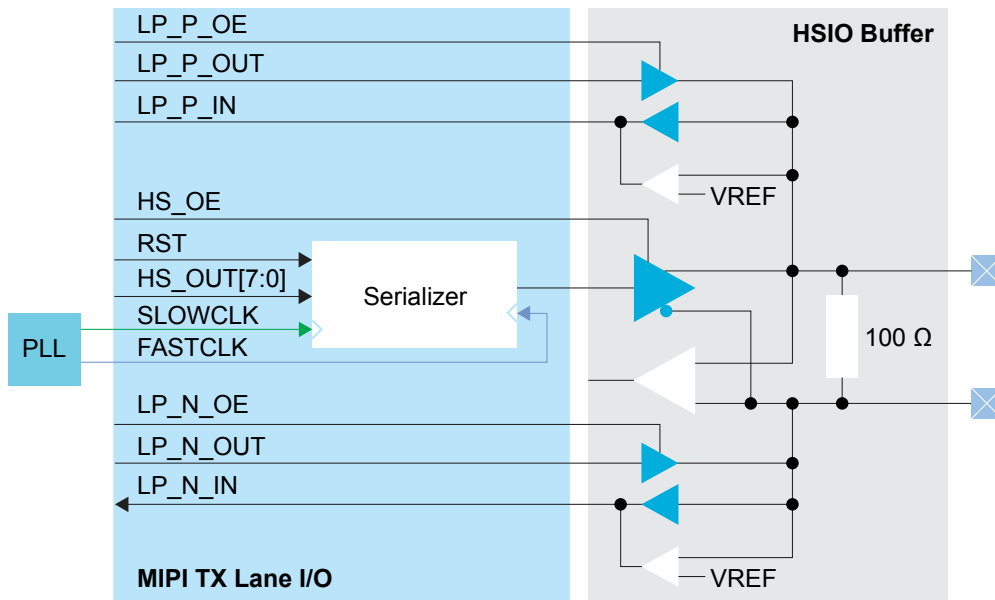

Table 21: MIPI TX Lane Signals

Interface to MIPI soft CSI/DSI controller with D-PHY in FPGA fabric

Signal	Direction	Clock Domain	Description
LP_P_OE	Input	–	LP output enable signal for P pad.
LP_P_OUT	Input	–	LP output data from the core for the P pad.
LP_P_IN	Output	–	(Optional) LP input data from the P pad. Used if data lane is reversible.
HS_OE	Input	–	High-speed output enable signal.
RST	Input	SLOWCLK	(Optional) Resets the serializer.
HS_OUT[7:0]	Input	SLOWCLK	High-speed output data from the core. Always 8-bits wide.
SLOWCLK	Input	–	Parallel (slow) clock.
FASTCLK	Input	–	Serial (fast) clock.
LP_N_OE	Input	–	LP output enable signal for N pad.
LP_N_OUT	Input	–	LP output data from the core for the N pad.
LP_N_IN	Output	–	(Optional) LP input data from the N pad. Used if data lane is reversible.

MIPI Lane Pads

Table 22: MIPI Lane Pads

Signal	Direction	Description
P	Output	Differential pad P.
N	Output	Differential pad N.

I/O Banks

Elitestek FPGAs have input/output (I/O) banks for general-purpose usage. Each I/O bank has independent power pins. The number and voltages supported vary by FPGA and package.

Tableome I/O banks are merged at the package level by sharing VCCIO pins, these are called merged banks. Merged banks have underscores (_) between banks in the VCCIO name (e.g., 1B_1C means VCCIO for bank 1B and 1C are connected). Some of the banks in a merged bank may not have available user I/Os in the package. The following table lists banks that have available user I/Os in a package.

Table 23: I/O Banks by Package

Package	I/O Banks	Voltage (V)	Dynamic Voltage Support	DDIO Support	Merged Banks
W64	1A, 1B, 3B	1.2, 1.5, 1.8	–	All	1A_4B, 1B_2A, 2B_3A_3B_4A
F100	1A, 2A	1.2, 1.5, 1.8	–	All	1A_4B, 2A_2B
	1B, 3A, 3B	1.2, 1.5, 1.8	–	All	3B_4A
	BL	1.8, 2.5, 3.0, 3.3	✓	All	–
F100S3F2	1A, 2A	1.2, 1.5, 1.8 ⁽⁶⁾	–	All	1A_4B, 2A_2B
	1B, 3A, 3B	1.2, 1.5, 1.8	–	All	3B_4A
	BL	1.8, 2.5, 3.0, 3.3	✓	All	–
F225 F256	BL, TL, TR, BR,	1.8, 2.5, 3.0, 3.3	✓	All	–
	1A, 1B, 2A, 2B, 3A, 3B, 4A, 4B	1.2, 1.5, 1.8	–	All	–



Learn more: Refer to the Ti60 Pinout (.xlsx) for information on the I/O bank assignments.

Oscillator

The Ti60 has one low-frequency oscillator tailored for low-power operation. The oscillator runs at a nominal frequency of 10, 20, 40, or 80 MHz. You can use the oscillator to perform always-on functions with the lowest power possible. Its output clock is available to the core. You can enable or disable the oscillator to allow power savings when not in use. The oscillator has:

- An output duty cycle of 45% to 55%.
- A $\pm 20\%$ frequency variation from device to device.

⁽⁶⁾ The SPI flash memory's VCC is connected to VCCIO1A_4B. If you are using the SPI flash memory, drive the VCCIO1A_4B with a 1.8 V supply.

PLL

Ti60 FPGAs have 4 PLLs to synthesize clock frequencies. The PLLs are located in the corners of the FPGA. You can use the PLL to compensate for clock skew/delay via external or internal feedback to meet timing requirements in advanced applications. The PLL reference clock has up to four sources. You can dynamically select the PLL reference clock with the `CLKSEL` port. (Hold the PLL in reset when dynamically selecting the reference clock source.)

The PLL consists of a pre-divider counter (N counter), a feedback multiplier counter (M counter), a post-divider counter (O counter), and output dividers (C).



Note: You can cascade PLLs. To avoid the PLL losing lock, Elitestek recommends that you do not cascade more than two PLLs.

Figure 32: PLL Block Diagram

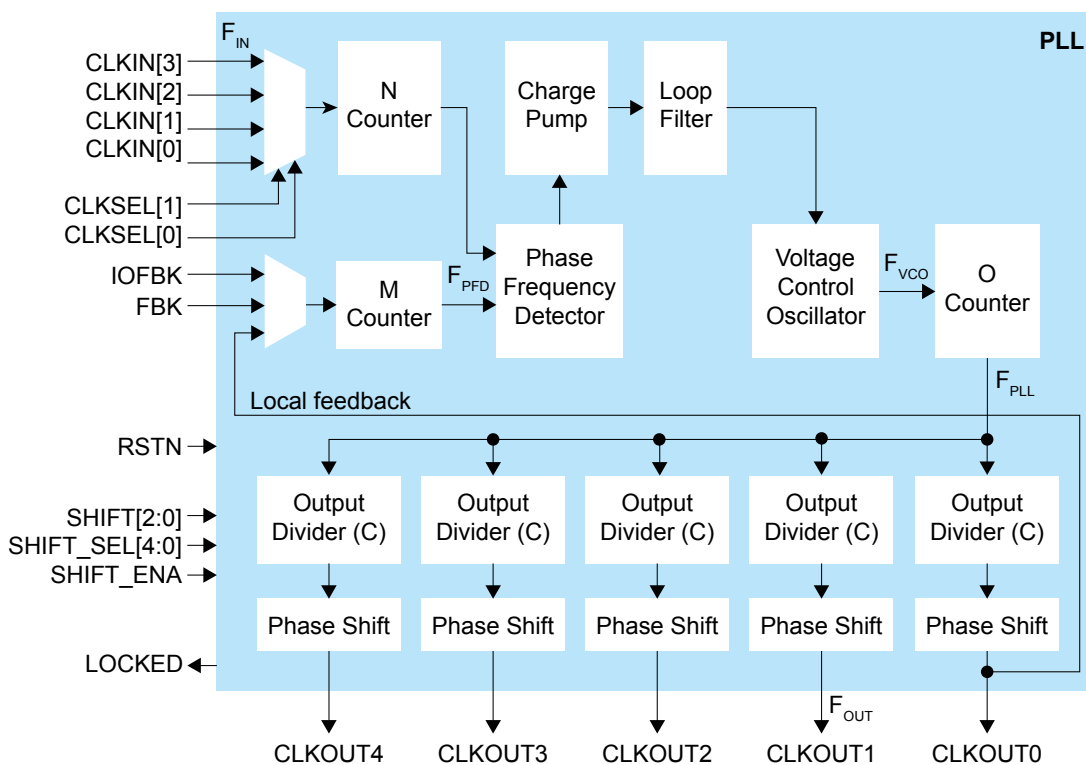

The counter settings define the PLL output frequency:

Local and Core Feedback Mode	Where:
$F_{PFD} = F_{IN} / N$ $F_{VCO} = (F_{PFD} \times M \times O \times C_{FBK})^{(7)}$ $F_{PLL} = F_{VCO} / O$ $F_{OUT} = (F_{IN} \times M \times C_{FBK}) / (N \times C)$	F_{VCO} is the voltage control oscillator frequency F_{PLL} is the post-divider PLL VCO frequency F_{OUT} is the output clock frequency F_{IN} is the reference clock frequency F_{PFD} is the phase frequency detector input frequency O is the post-divider counter C is the output divider



Note: Refer to the Page63 **PLL Timing and AC Characteristics** for F_{VCO} , F_{OUT} , F_{IN} , F_{PLL} , and F_{PFD} values.

⁽⁷⁾ $(M \times O \times C_{FBK})$ must be ≤ 255 .

Figure 33: PLL Interface Block Diagram

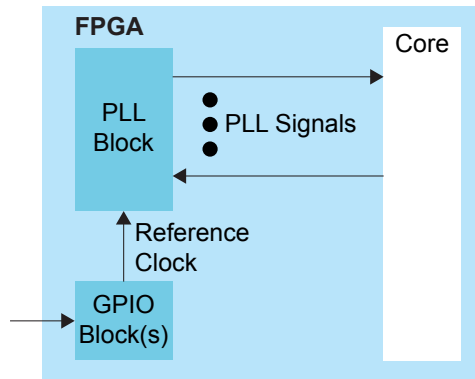

Table 24: PLL Signals (Interface to FPGA Fabric)

Signal	Direction	Description
CLKIN[3:0]	Input	Reference clocks driven by I/O pads or core clock tree.
CLKSEL[1:0]	Input	You can dynamically select the reference clock from one of the clock in pins.
RSTN	Input	Active-low PLL reset signal. When asserted, this signal resets the PLL; when de-asserted, it enables the PLL. De-assert only when the CLKIN signal is stable. Connect this signal in your design to power-up or reset the PLL. Assert the RSTN pin for a minimum pulse of 10 ns to reset the PLL. Assert RSTN when dynamically changing the selected PLL reference clock.
FBK	Input	Connect to a clock out interface pin when the PLL is in core feedback mode.
IOFBK	Input	Connect to a clock out interface pin when the PLL is in external I/O feedback mode.
CLKOUT0 CLKOUT1 CLKOUT2 CLKOUT3 CLKOUT4	Output	PLL output. You can route these signals as input clocks to the core's GCLK network. CLKOUT4 can only feed the top or bottom regional clocks. All PLL outputs lock on the negative clock edge. The Interface Designer inverts the clock polarity on the leaf cells by default (Output Clock Inversion option unchecked). Check the option if you are using the clock to drive core logic. You can use CLKOUT0 only for clocks with a maximum frequency of 4x (integer) of the reference clock. If all your system clocks do not fall within this range, you should dedicate one unused clock for CLKOUT0.
LOCKED	Output	Goes high when PLL achieves lock; goes low when a loss of lock is detected. Connect this signal in your design to monitor the lock status. This signal is not synchronized to any clock and the minimum high or low pulse width of the lock signal may be smaller than the CLKOUT' s period.
SHIFT[2:0]	Input	(Optional) Dynamically change the phase shift of the output selected to the value set with this signal. Possible values from 000 (no phase shift) to 111 (3.5 F _{PLL} cycle delay). Each increment adds 0.5 cycle delay.
SHIFT_SEL[4:0]	Input	(Optional) Choose the output(s) affected by the dynamic phase shift.
SHIFT_ENA	Input	(Optional) When high, changes the phase shift of the selected PLL(s) to the new value.

Table 25: PLL Reference Clock Resource Assignments (W64)

PLL	REFCLK0	REFCLK1	REFCLK2	External Feedback I/O
PLL_TL	Single-ended: GPIOL_P_18_PLLIN0 Differential: GPIOL_P_18_PLLIN0, GPIOL_N_18	Unbonded ⁽⁸⁾	Unbonded ⁽⁸⁾	Single-ended: GPIOL_P_17_EXTFB Differential: GPIOL_P_17_EXTFB, GPIOL_N_17
PLL_BR	Single-ended: GPIOR_P_00_PLLIN0 Differential: GPIOR_P_00_PLLIN0, GPIOR_N_00_CDI22	Unbonded ⁽⁸⁾	Unbonded ⁽⁸⁾	Single-ended: GPIOR_P_01_EXTFB Differential: GPIOR_P_01_EXTFB, GPIOR_N_01_CDI23

Table 26: PLL Reference Clock Resource Assignments (F100 and F100S3F2)

PLL	REFCLK0	REFCLK1	REFCLK2	External Feedback I/O
PLL_TL	Single-ended: GPIOL_P_18_PLLIN0 Differential: GPIOL_P_18_PLLIN0, GPIOL_N_18	Unbonded ⁽⁸⁾	Unbonded ⁽⁸⁾	Single-ended: GPIOL_P_17_EXTFB Differential: GPIOL_P_17_EXTFB, GPIOL_N_17
PLL_TR	Single-ended: GPIOR_P_19_PLLIN0 Differential: GPIOR_P_19_PLLIN0, GPIOR_N_19	Unbonded ⁽⁸⁾	Unbonded ⁽⁸⁾	Unbonded ⁽⁸⁾
PLL_BR	Single-ended: GPIOR_P_00_PLLIN0 Differential: GPIOR_P_00_PLLIN0, GPIOR_N_00_CDI22	Unbonded ⁽⁸⁾	Unbonded ⁽⁸⁾	Single-ended: GPIOR_P_01_EXTFB Differential: GPIOR_P_01_EXTFB, GPIOR_N_01_CDI23

Table 27: PLL Reference Clock Resource Assignments (F225 and F256)

PLL	REFCLK0	REFCLK1	REFCLK2	External Feedback I/O
PLL_BL	Single-ended: GPIOL_P_00_PLLIN0 Differential: GPIOL_P_00_PLLIN0, GPIOL_N_00	Single-ended: GPIOB_P_00_PLLIN1 Differential: GPIOB_P_00_PLLIN1, GPIOB_N_00	Unbonded ⁽⁸⁾	Single-ended: GPIOB_P_01_EXTFB Differential: GPIOB_P_01_EXTFB, GPIOB_N_01
PLL_TL	Single-ended: GPIOL_P_18_PLLIN0 Differential: GPIOL_P_18_PLLIN0, GPIOL_N_18	Single-ended: GPIOT_P_00_PLLIN1 Differential: GPIOT_P_00_PLLIN1, GPIOT_N_00	GPIOL_11_PLLIN2	Single-ended: GPIOL_P_17_EXTFB Differential: GPIOL_P_17_EXTFB, GPIOL_N_17
PLL_TR	Single-ended: GPIOR_P_19_PLLIN0 Differential: GPIOR_P_19_PLLIN0, GPIOR_N_19	Single-ended: GPIOT_P_17_PLLIN1 Differential: GPIOT_P_17_PLLIN1, GPIOT_N_17	Unbonded ⁽⁸⁾	Single-ended: GPIOT_P_16_EXTFB Differential: GPIOT_P_16_EXTFB, GPIOT_N_16
PLL_BR	Single-ended: GPIOR_P_00_PLLIN0 Differential: GPIOR_P_00_PLLIN0, GPIOR_N_00_CDI22	Single-ended: GPIOB_P_17_PLLIN1 Differential: GPIOB_P_17_PLLIN1, GPIOB_N_17	GPIOR_29_PLLIN2	Single-ended: GPIOR_P_01_EXTFB Differential: GPIOR_P_01_EXTFB, GPIOR_N_01_CDI23

⁽⁸⁾ There is no dedicated pin assigned to this reference clock.

Dynamic Phase Shift

Ti60 FPGAs support a dynamic phase shift where you can adjust the phase shift of each output dynamically in user mode by up to 3.5 F_{PLL} cycles. For example, to phase shift a 400 MHz clock by 90-degree, configure the PLL to have a F_{PLL} frequency of 800 MHz, set the output counter division to 2, and set `SHIFT[2:0]` to 001.

Implementing Dynamic Phase Shift

Use these steps to implement the dynamic phase shift:

1. Write the new phase setting into `SHIFT[2:0]`.
2. After 1 clock cycle of the targeted output clock that you want to shift, assert the `SHIFT_SEL[n]` and `SHIFT_ENA` signals.
3. Hold `SHIFT_ENA` and `SHIFT_SEL[n]` high for a minimum period of 4 clock cycles of the targeted output clock.
4. De-assert `SHIFT_ENA` and `SHIFT_SEL[n]`. Wait for at least 4 clock cycles of the targeted output clock before asserting `SHIFT_ENA` and `SHIFT_SEL[n]` again.



Note: n in `SHIFT_SEL[n]` represents the output clock that you intend to add phase shift.

The following waveforms describe the signals for a single phase shift and consecutive multiple phase shifts.

Figure 34: Single Dynamic Phase Shift Waveform Example for CLKOUT1

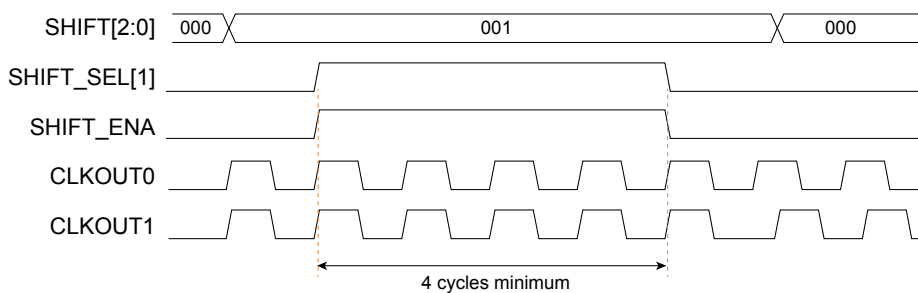
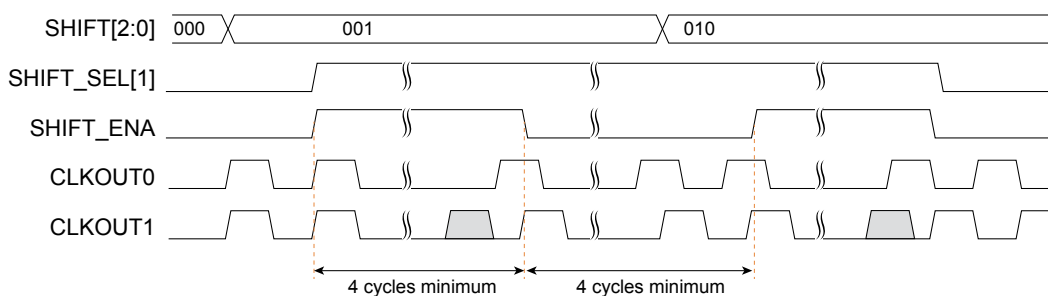

Figure 35: Consecutive Dynamic Phase Shift Waveform Example for CLKOUT1



SPI Flash Memory

Ti60 FPGAs in the F100S3F2 package include a SPI flash memory. The SPI flash memory has a density of 16 Mbits and a clock rate of up to 85 MHz. In active configuration mode, the FPGA is configured using the configuration bitstream in the SPI flash memory. Typically you can fit two compressed bitstream images into the F100S3F2 SPI flash.



Important: You cannot enable the Ti60 FPGA security features when using compressed bitstreams.

To use active programming mode for the Ti60 F100S3F2 with the SPI flash memory, you must use the SPI Active using JTAG Bridge configuration mode to configure the SPI flash memory.



Learn more: Refer to the AN 033: Configuring TJ-Series FPGAs for information on programming the SPI flash memory.

Figure 36: SPI Flash Memory Block Diagram

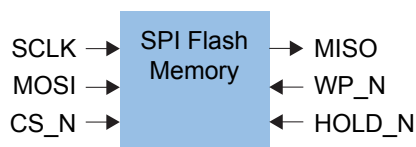

Important: The SPI flash memory's VCC is connected to VCCIO1A_4B. If you are using the SPI flash memory, drive the VCCIO1A_4B with a 1.8 V supply.

Table 28: SPI Flash Memory Signals (Interface to FPGA Fabric)

SPI Name	Signal	Direction	Description
SCLK	SCLK_OUT	Input	Clock output from FPGA CCK pin to SPI flash memory.
	SCLK_OE	Input	Output enable. Required for multiple controller.
MOSI	MOSI_IN	Output	Required for x2 or x4 data width.
	MOSI_OUT	Input	Data output from FPGA CDI0 to SPI flash memory.
	MOSI_OE	Input	Output enable. Required for x2 data width, x4 data width, or multiple controller.
MISO	MISO_IN	Output	Data input to FPGA CDI1 from SPI flash memory.
	MISO_OUT	Input	Required for x2 or x4 data width.
	MISO_OE	Input	Output enable. Required for x2 or x4 data width.
WP_N	WP_N_IN	Output	Required for x4 data width.
	WP_N_OUT	Input	Data output from FPGA CDI2 pin to SPI flash memory.
	WP_N_OE	Input	Output enable. Required for x4 data width or multiple controller.
HOLD_N	HOLD_N_IN	Output	Required for x4 data width.
	HOLD_N_OUT	Input	Data output from FPGA CDI3 pin to SPI flash memory
	HOLD_N_OE	Input	Output enable. Required for x4 data width or multiple controller.
CS_N	CS_N_OUT	Input	Chip select output from FPGA SSL_N pin to SPI flash memory.
	CS_N_OE	Input	Output enable. Required for multiple controller.
CLK	CLK	Input	Required for register interface.



Important: Pins GPIOL_P_01, GPIOL_N_01, GPIOL_P_03, and GPIOL_N_03 are not available as user I/Os if you enable the SPI flash memory access during user mode. Refer to the TJ-Series Interfaces User Guide for information about enabling the SPI flash memory during user mode to store user data.

HyperRAM

The Ti60 FPGA in F100S3F2 package includes a HyperRAM. The HyperRAM has a density of 256 Mbits and a clock rate of up to 200 MHz. The HyperRAM supports double-data rates of up to 400 Mbps and supports a 16 bit data bus.

Figure 37: HyperRAM Block Diagram

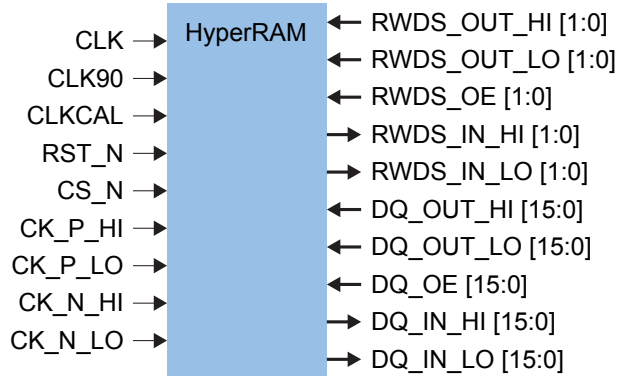

Important: The HyperRAM's VCC is connected to VCCIO_2A_2B. If you are using the HyperRAM, drive the VCCIO_2A_2B with a 1.8 V supply.

Table 29: HyperRAM Signals (Interface to FPGA Fabric)

Signal	Direction	Description
CLK	Input	HyperRAM controller clock.
CLK90	Input	90 degree phase-shifted version of CLK.
CLKCAL	Input	Calibration clock for input data.
RST_N	Input	Active-low HyperRAM reset.
CS_N	Input	Active-low HyperRAM chip select signal.
CK_P_HI	Input	The clock provided to the HyperRAM. The clock is not required to be free-running. Registered in normal mode of DDIO.
CK_P_LO	Input	
CK_N_HI	Input	
CK_N_LO	Input	
RWDS_OUT_HI [1:0]	Input	Read/write data strobe input ports for data mask during write operation. Registered in normal mode/resync mode of DDIO.
RWDS_OUT_LO [1:0]	Input	
RWDS_OE [1:0]	Input	Read/write data strobe output enable port.
RWDS_IN_HI [1:0]	Output	Read/write data strobe output ports for latency indication, also center-aligned reference strobe for read data. Registered in normal mode/resync mode of DDIO.
RWDS_IN_LO [1:0]	Output	
DQ_OUT_HI [15:0]	Input	DQ input ports for command, address and data. Registered in normal mode of DDIO.
DQ_OUT_LO [15:0]	Input	
DQ_OE [15:0]	Input	DQ output enable port.
DQ_IN_HI [15:0]	Output	DQ output ports for data.
DQ_IN_LO [15:0]	Output	

Single-Event Upset Detection

The Ti60 FPGA has a hard block for detecting single-event upset (SEU). The SEU detection feature has two modes:

- Auto mode—The Ti60 control block periodically runs SEU error checks and flags if it detects an error. You can configure the interval time between SEU checks.
- Manual mode—The user design runs the check.

In both modes, the user design is responsible for deciding whether to reconfigure the Ti60 when an error is detected.



Learn more: For more information on using the SEU detection feature, refer to the TJ-Series Interfaces User Guide.

Internal Reconfiguration Block

The Ti60 FPGAs have built-in hardware that supports an internal reconfiguration feature. The Ti60 can reconfigure itself from a bitstream image stored in flash memory.

Security Feature

The Ti60 FPGA security feature⁽⁹⁾ includes:

- Intellectual property protection using bitstream encryption with the AES-GCM-256 algorithm
- Anti-tampering support using asymmetric bitstream authentication with the RSA-4096 algorithm



Important: You cannot enable the Ti60 FPGA security features when using compressed bitstreams.

You can enable encryption, authentication, or both. You enable the security features at the project level.

Figure 38: Security Flow

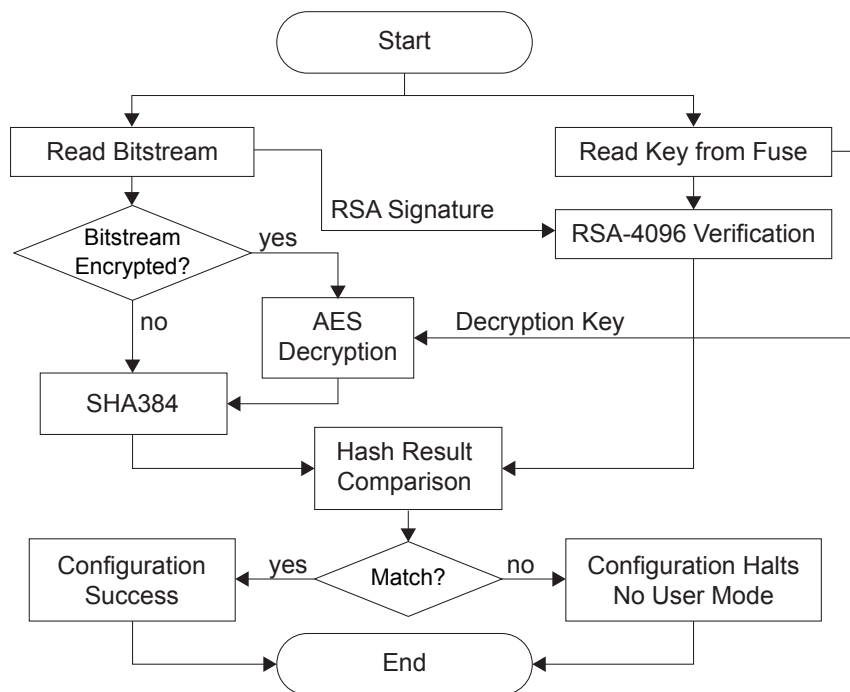

Down: Refer to the Securing TJ-Series Bitstreams section of the Configuring an FPGA chapter in the Efinity Software User Guide for instructions on how to enable these features.

Bitstream Encryption

Symmetric bitstream encryption uses a 256-bit key and the AES-GCM-256 algorithm. You create the key and then use it to encrypt the bitstream. You also need to store the key into the FPGA's fuses. During configuration, the Ti60 built-in AES-GCM-256 engine decrypts the encrypted configuration bitstream using the stored key. Without the correct key, the bitstream decryption process cannot recover the original bitstream.

⁽⁹⁾ The security feature is not supported for W64 packages. See [PCN-2405-002](#) for details.

Bitstream Authentication

For bitstream authentication, you use a public/private key pair and the RSA-4096 algorithm. You create a public/private key pair and sign the bitstream with the private key. Then, you save a hashed version of the public key into fuses in the FPGA. During configuration, the FPGA validates the signature on the bitstream using the public key.

If the signature is valid, the FPGA knows that the bitstream came from a trusted source and has not been altered by a third party. The FPGA continues configuring normally and goes into user mode. If the signature is invalid, the FPGA stops configuration and does not go into user mode.

The private key remains on your computer and is not shared with anyone. The FPGA only has the public key: the bitstream contains the public key data and a signature, while the fuses contain a hashed public key. You can only sign the bitstream with the private key. An attacker cannot re-sign a tampered bitstream without the private key.

Disabling JTAG Access

Ti60 FPGA's support JTAG blocking, which disables JTAG access to the FPGA by blowing a fuse. Once the fuse is blown, you cannot perform any JTAG operation except for reading the FPGA `IDCODE`, reading `DEVICE_STATUS`, and enabling `BYPASS` mode. To fully secure the FPGA, you **must** blow the JTAG fuse.



Important: Once you blow the fuse, however, you cannot use JTAG ever again in that FPGA (except for `IDCODE`, `DEVICE_STATUS`, and `BYPASS`). So blowing this fuse should be the very last step in your manufacturing process.

Fuse Programming Requirements



Important: These requirements apply to:

- All F100 and F256 packages
- F100S3F2 and F225 packages with the letter `s` in the lot number

Ti60 FPGAs in F100S3F2 and F225 packages that **do not** have the letter `s` in the lot number do not have these requirements.

To program the security fuses in FPGA, follow these requirements:

- During fuse programming, avoid device configuration and other JTAG operations that are not related to fuse programming.
- Ramp up the `VQPS` pin only after all other power supplies have ramped to their nominal voltages. The `VQPS` ramp rate follows the requirements shown in the Page55 [Table 37: Power Supply Ramp Rates](#).
- After powering up the `VQPS` pin, wait for a minimum of 10 ms before issuing JTAG instructions for fuse programming.
- After completing fuse programming through JTAG, wait for a minimum of 10 ms before powering down the `VQPS` pin. If required, other power supplies can be powered down only after the `VQPS` pin has been powered down below 25 % of its nominal voltage level.

Figure 39: Fuse Programming Waveform

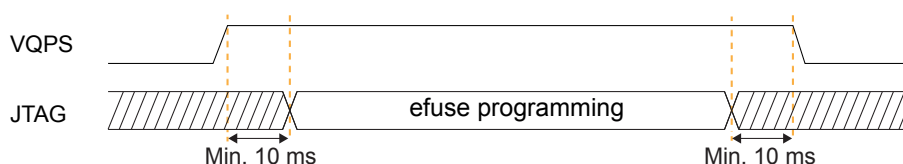

Learn more: Refer to the Securing Titanium Bitstream section in the Efinity Programmer User Guide.

Power Sequence



Important: You **must** follow the power-up and power-down sequence when powering TJ-Series FPGAs.

Power-Up Sequence (No VQPS)



Important: This sequence applies to Ti60 FPGAs in W64 packages and F100S3F2 and F225 packages that **do not** have the letter *s* in the lot number. For F100S3F2 and F225 packages with the letter *s* in the lot number as well as F100 and F256 packages (all lots), refer to Page50 **Power-Up Sequence (VQPS)**. See **PCN-2405-001** for details.

You **must** use the following power-up sequence:

Figure 40: Power-Up Sequence

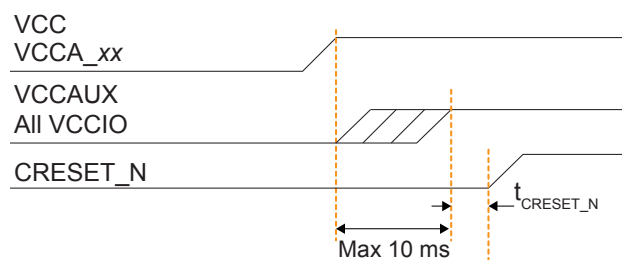

1. Power-up VCC and $VCCA_xx$ first. These supplies can be powered up in any sequence.
2. When VCC and $VCCA_xx$ are stable, power-up all $VCCIO$ and $VCCAUX$. These supplies can be powered up in any sequence.



Important: Ensure the power ramp rate is within the Page55 **Table 37: Power Supply Ramp Rates**.

3. After all power supplies are stable, hold $CRESET_N$ low for a duration of t_{CRESET_N} before releasing $CRESET_N$ from low to high.



Note: With the configuration bitstream stored in the SPI flash device and the SPI active hardware connection properly established, the SPI active configuration automatically starts after the $CRESET_N$ signal transitions from low to high.



Note: Refer to Page64 **Configuration Timing** for configuration timing information.

Table 30: Connection Requirements for Unused Resources and Features

Unused Resource/Feature	Pin	Note
PLL	VCCA_xx	Connect to VCC.
HSIO Bank	VCCIOxx	Connect to either 1.2 V, 1.5 V, or 1.8 V.
HVIO Bank	VCCIO33_xx	Connect to either 1.8 V, 2.5 V, 3.0 V, or 3.3 V.



Learn more: Refer to TJ-Series Hardware Design Checklist and Guidelines for connection requirements for unused resources.

Power-Up Sequence (VQPS)



Important: This sequence applies to Ti60 FPGAs in F100 and F256 packages (all lots) as well as F100S3F2 and F225 packages **with** the letter *s* in the lot number. For F100S3F2 and F225 packages that do not have the letter *s* in the lot number, refer to Page 49 **Power-Up Sequence (No VQPS)**. See **PCN-2405-001** for details.

Figure 41: Power-Up Sequence

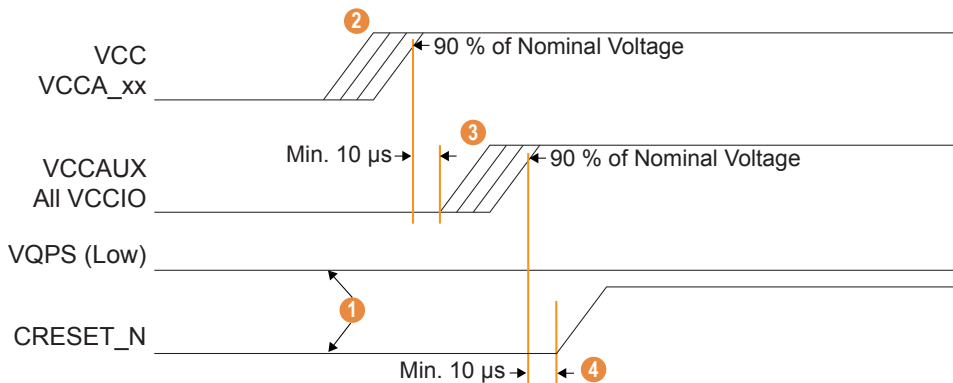

1. The `CRESET_N` input must stay **low** until all power supplies are powered up. Additionally, `VQPS` must **always** stay **low** unless you are blowing the Ti60 security fuses.



Note: Refer to Page 48 **Fuse Programming Requirements** if you need to blow the security fuses for the Ti60 FPGA on your board.

2. Power up `VCC` and `VCCA_xx` first. You can power up these supplies in any sequence.



Important: Ensure the power ramp rate is within the values shown in Page 55 **Table 37: Power Supply Ramp Rates**.

3. Power up all `VCCIO` and `VCCAUX` in any sequence at a minimum delay of 10 μ s after the `VCC` and `VCCA_xx` supplies have reached 90% of their nominal voltage levels.
4. Release the `CRESET_N` input to high at a minimum delay of 10 μ s after all supplies have reached 90% of their nominal voltage levels.



Note: With the configuration bitstream stored in the SPI flash device and the SPI active hardware connection properly established, the SPI active configuration automatically starts after the `CRESET_N` signal transitions from low to high.

Table 31: Connection Requirements for Unused Resources and Features

Unused Resource/Feature	Pin	Note
PLL	VCCA	Connect to VCC.
HSIO Bank	VCCIO	Connect to either 1.2 V, 1.5 V, or 1.8 V.
HVIO Bank	VCCIO33	Connect to either 1.8 V, 2.5 V, 3.0 V, or 3.3 V.
Security (Fuse Blowing)	VQPS	Connect to GND.



Learn more: Refer to TJ-Series Hardware Design Checklist and Guidelines for connection requirements for unused resources.

Power-Down Sequence

There is no specific power-down sequence for Ti60 FPGAs. However, the V_{QPS} power supply **must** follow the specifications in Page 48 **Fuse Programming Requirements** for the following packages:

- F100 and F256 (all lots)
- F100S3F2 and F225 packages with the letter S in the lot number

Power Supply Current Transient

You may observe an inrush current on the dedicated power rail during power-up. You must ensure that the power supplies selected in your board meets the current requirement during power-up and the estimated current during user mode. Use the Power Estimator to calculate the estimated current during user mode.

Table 32: Minimum Power Supply Current Transient

Power Supply	Minimum Power Supply Current Transient	Unit
VCC	500	mA

Configuration

The Ti60 FPGA contains volatile Configuration RAM (CRAM). The user must configure the CRAM for the desired logic function upon power-up and before the FPGA enters normal operation. The FPGA's control block manages the configuration process and uses a bitstream to program the CRAM. The Efinity[®] software generates the bitstream, which is design dependent. You can configure the Ti60 FPGA(s) in SPI active, SPI passive, or JTAG mode.

Figure 42: High-Level Configuration Options

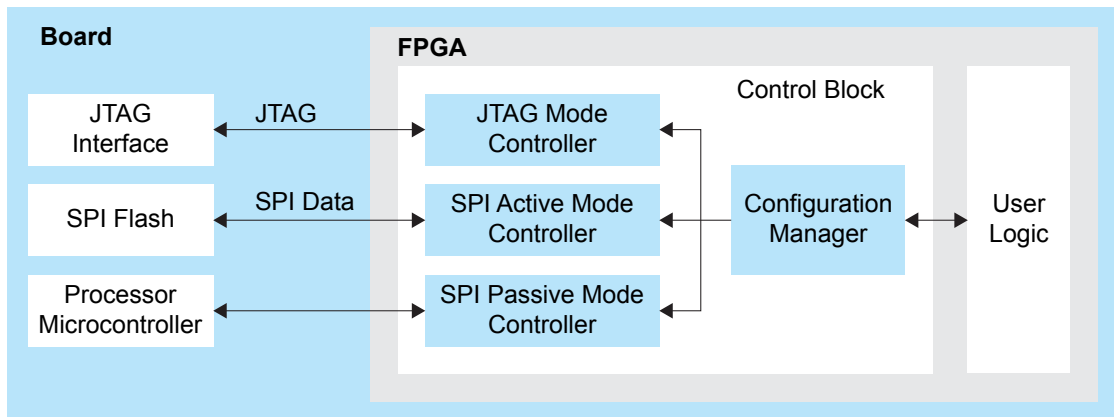

In active mode, the FPGA controls the configuration process. The configuration clock can either be provided by an oscillator circuit within the FPGA or an external clock connected to the `EXT_CONFIG_CLK` pin. The bitstream is typically stored in an external serial flash device, which provides the bitstream when the FPGA requests it.

The control block sends out the instruction and address to read the configuration data. First, it issues a release from power-down instruction to wake up the external SPI flash. Then, it waits for at least 30 μ s before issuing a fast read command to read the content of SPI flash from address `24h' 000000`.

In passive mode, the FPGA is the slave and relies on an external master to provide the control, bitstream, and clock for configuration. Typically the master is a microcontroller or another FPGA in active mode. The controller must wait for at least 32 μ s after `RESET` is de-asserted before it can send the bitstream.

In JTAG mode, you configure the FPGA via the JTAG interface.

Supported FPGA Configuration Modes

Table 33: Ti60 Configuration Modes by Package

Configuration Mode	Width	W64	F100	F100S3F2	F225, F256
Active	X1	✓	✓	✓ ⁽¹⁰⁾	✓
	X2	✓	✓	✓ ⁽¹⁰⁾	✓
	X4	✓	–	✓ ⁽¹⁰⁾	✓
	X8	–	–	–	✓
Passive	X1	✓	✓	✓	✓
	X2	✓	✓	✓	✓
	X4	✓	–	–	✓
	X8	–	–	–	✓
	X16	–	–	–	✓ ⁽¹¹⁾
	X32	–	–	–	✓ ⁽¹¹⁾
JTAG	X1	✓	✓	✓	✓



Learn more: Refer to AN 033: Configuring TJ-Series FPGAs for more information.

⁽¹⁰⁾ SPI active configuration supported with the in-package SPI flash.

⁽¹¹⁾ Not supported when security mode is enabled.

Characteristics and Timing

The following table shows the specification status for Ti60 packages.

Table 34: Package Status

Package	Status
F100, F256	Preliminary
W64, F100S3F2, F225	Final

DC and Switching Characteristics

Table 35: Absolute Maximum Ratings⁽¹²⁾

Conditions beyond those listed may cause permanent damage to the device. Device operation at the absolute maximum ratings for extended periods of time has adverse effects on the device.

Symbol	Description	Min	Max	Units
VCC	Core power supply.	-0.5	1.05	V
VCCA	PLL analog power supply.	-0.5	1.05	V
VCCAUX	1.8 V auxiliary power supply.	-0.5	1.98	V
VQPS	1.8 V security fuse supply.	-0.5	1.98	V
VCCIO	HSIO bank power supply.	-0.5	1.98	V
VCCIO33	HVIO bank power supply.	-0.5	3.63	V
I _{IN}	Maximum current allowed through any I/O pin when the device is not turned on or during power-up/down. ⁽¹³⁾	–	10	mA
V _{IN}	HVIO input voltage.	-0.5	3.63	V
	HSIO input voltage.	-0.5	1.98	V
T _J	Operating junction temperature.	-40	125	°C
T _{STG}	Storage temperature, ambient.	-55	150	°C

⁽¹²⁾ Supply voltage specification applied to the voltage taken at the device pins with respect to ground, not at the power supply.

⁽¹³⁾ Should not exceed a total of 100 mA per bank

Table 36: Recommended Operating Conditions ⁽¹²⁾

Symbol	Description	Min	Typ	Max	Units
VCC	C3L, C4L, I3L speed grade core power supply.	0.82	0.85	0.88	V
	C3, C4, I3, Q3 speed grade core power supply.	0.92	0.95	0.98	V
VCCA	C3L, C4L, I3L speed grade PLL analog power supply.	0.82	0.85	0.88	V
	C3, C4, I3, Q3 speed grade PLL analog power supply.	0.92	0.95	0.98	V
VCCAUX	1.8 V auxiliary power supply.	1.75	1.8	1.85	V
VQPS	1.8 V security fuse supply.	1.71	1.8	1.89	V
VCCIO	1.2 V HSIO bank power supply.	1.14	1.2	1.26	V
	1.35 V HSIO bank power supply	1.283	1.35	1.417	V
	1.5 V HSIO bank power supply.	1.425	1.5	1.575	V
	1.8 V HSIO bank power supply.	1.71	1.8	1.89	V
VCCIO33	1.8 V HVIO bank power supply.	1.71	1.8	1.89	V
	2.5 V HVIO bank power supply.	2.375	2.5	2.625	V
	3.0 V HVIO bank power supply.	2.85	3.0	3.15	V
	3.3 V HVIO bank power supply.	3.135	3.3	3.465	V
T _{JCOM}	Operating junction temperature, commercial.	0	–	85	°C
T _{JIND}	Operating junction temperature, industrial.	-40	–	100	°C
T _{JAUTO}	Operating junction temperature, automotive.	-40	–	125	°C

Table 37: Power Supply Ramp Rates

Symbol	Description	Min	Max	Units
t _{RAMP}	Power supply ramp rate for all supplies.	0.1 * V _{supply}	10	V/ms

Table 38: HVIO DC Electrical Characteristics

I/O Standard	V _{IL} (V)		V _{IH} (V)		V _{OL} (V)	V _{OH} (V)
	Min	Max	Min	Max	Max	Min
3.3 V LVCMOS	-0.3	0.8	2.1	3.465	0.2	VCCIO33 - 0.2
3.0 V LVCMOS	-0.3	0.8	2.1	3.15	0.2	VCCIO33 - 0.2
3.3 V LVTTTL	-0.3	0.8	2.1	3.465	0.4	2.4
3.0 V LVTTTL	-0.3	0.8	2.1	3.15	0.4	2.4
2.5 V LVCMOS	-0.3	0.45	1.7	2.625	0.4	2.0
1.8 V LVCMOS	-0.3	0.58	1.27	1.89	0.45	VCCIO33 - 0.45
1.8 V LVCMOS (JTAG) ⁽¹⁴⁾	-0.3	0.28	1.27	1.89	0.45	VCCIO33 - 0.45

Table 39: HVIO DC Electrical Characteristics

Voltage (V)	Typical Hysteresis (mV) ⁽¹⁵⁾	Input Leakage Current (µA)	Tristate Output Leakage Current (µA)
3.3	250	±10	±10
2.5	250	±10	±10
1.8	200	±10	±10

⁽¹⁴⁾ For JTAG configuration mode⁽¹⁵⁾ For input pins with Schmitt Trigger enabled

Table 40: HSIO Pins Configured as Single-Ended I/O DC Electrical Characteristics

I/O Standard	V _{IL} (V)		V _{IH} (V)		V _{OL} (V)	V _{OH} (V)
	Min	Max	Min	Max	Max	Min
1.8 V LVCMOS	-0.3	0.58	1.27	1.89	0.45	VCCIO - 0.45
1.5 V LVCMOS	-0.3	0.35 * VCCIO	0.65 * VCCIO	1.575	0.25 * VCCIO	0.75 * VCCIO
1.2 V LVCMOS	-0.3	0.35 * VCCIO	0.65 * VCCIO	1.26	0.25 * VCCIO	0.75 * VCCIO
1.8 V HSTL	–	VREF - 0.1	VREF + 0.1	–	0.4	VCCIO - 0.4
1.5 V HSTL	–	VREF - 0.1	VREF + 0.1	–	0.4	VCCIO - 0.4
1.2 V HSTL	-0.15	VREF - 0.08	VREF + 0.08	VREF + 0.15	0.25 * VCCIO	0.75 * VCCIO
1.8 V SSTL	-0.3	VREF - 0.125	VREF + 0.125	VCCIO + 0.3	VTT - 0.603	VTT + 0.603
1.5 V SSTL	–	VREF - 0.1	VREF + 0.1	–	0.2 * VCCIO	0.8 * VCCIO
1.35 V SSTL	–	VREF - 0.1	VREF + 0.1	–	0.2 * VCCIO	0.8 * VCCIO
1.2 V SSTL	–	VREF - 0.1	VREF + 0.1	–	0.2 * VCCIO	0.8 * VCCIO

Table 41: HSIO Pins Configured as Single-Ended I/O DC Electrical Characteristics

I/O Standard	VREF (V)			V _{tt} (V)		
	Min	Typ	Max	Min	Typ	Max
1.8 V HSTL	0.85	0.9	0.95	–	0.5 * VCCIO	–
1.5 V HSTL	0.68	0.75	0.9	–	0.5 * VCCIO	–
1.2 V HSTL	0.47 * VCCIO	0.5 * VCCIO	0.53 * VCCIO	–	0.5 * VCCIO	–
1.8 V SSTL	0.833	0.9	0.969	VREF - 0.04	VREF	VREF + 0.04
1.5 V SSTL	0.49 * VCCIO	0.5 * VCCIO	0.51 * VCCIO	0.49 * VCCIO	0.5 * VCCIO	0.51 * VCCIO
1.35 V SSTL	0.49 * VCCIO	0.5 * VCCIO	0.51 * VCCIO	0.49 * VCCIO	0.5 * VCCIO	0.51 * VCCIO
1.2 V SSTL	0.49 * VCCIO	0.5 * VCCIO	0.51 * VCCIO	0.49 * VCCIO	0.5 * VCCIO	0.51 * VCCIO

Table 42: HSIO Pins Configured as Differential SSTL I/O Electrical Characteristics

I/O Standard	V _{SWING (DC)} (V)		V _{X(AC)} (V)			V _{SWING (AC)} (V)	
	Min	Max	Min	Typ	Max	Min	Max
1.8 V SSTL	0.25	VCCIO + 0.6	VCCIO/2 – 0.175	–	VCCIO/2 + 0.175	0.5	VCCIO + 0.6
1.5 V SSTL	0.2	–	VCCIO/2 – 0.15	–	VCCIO/2 + 0.15	0.35	–
1.35 V SSTL	0.2	–	VCCIO/2 – 0.15	–	VCCIO/2 + 0.15	0.35	–
1.2 V SSTL	0.18	–	VREF– 0.15	VCCIO /2	VREF + 0.15	-0.3	0.3

Table 43: HSIO Pins Configured as Differential HSTL I/O Electrical Characteristics

I/O Standard	V _{DIF (DC)} (V)		V _{X (AC)} (V)			V _{CM (DC)} (V)			V _{DIF (AC)} (V)	
	Min	Max	Min	Typ	Max	Min	Typ	Max	Min	Max
1.8 V HSTL	0.2	–	0.78	–	1.12	0.78	–	1.12	0.4	–
1.5 V HSTL	0.2	–	0.68	–	0.9	0.68	–	0.9	0.4	–
1.2 V HSTL	0.16	VCCIO + 0.3	–	0.5 * VCCIO	–	0.4 * VCCIO	0.5 * VCCIO	0.6 * VCCIO	0.3	VCCIO + 0.48

Table 44: HSIO Pins Configured as Single-Ended I/O DC Electrical Characteristics

Voltage (V)	Typical Hysteresis (mV) ⁽¹⁶⁾	Input Leakage Current (μ A)	Tristate Output Leakage Current (μ A)
1.8	200	± 10	± 10
1.5	160	± 10	± 10
1.35	–	± 10	± 10
1.2	140	± 10	± 10

Table 45: Supported HVIO Drive Strength

I/O Standard	Drive Strength	Units
3.3 V LVTTTL	4, 8, 12, 16	mA
3.3 V LVCMOS	2, 4, 6, 8	mA
3.0 V LVTTTL	4, 8, 12, 16	mA
3.0 V LVCMOS	2, 4, 6, 8	mA
2.5 V LVCMOS	4, 8, 12, 16	mA
1.8 V LVCMOS	4, 8, 12, 16	mA

Table 46: Supported HSIO Drive Strength

I/O Standard	Drive Strength	Units
1.8 V LVCMOS	4, 8, 12, 16	mA
1.5 V LVCMOS	4, 8, 12, 16	mA
1.2 V LVCMOS	2, 4, 8, 12	mA
1.8 V SSTL	4, 8, 10, 12	mA
1.5 V SSTL	4, 8, 10, 12	mA
1.35 V SSTL	4, 8, 10, 12	mA
1.2 V SSTL	4, 8, 10, 12	mA
1.8 V HSTL	4, 8, 10, 12	mA
1.5 V HSTL	4, 8, 10, 12	mA
1.2 V HSTL	4, 8, 10, 12	mA

⁽¹⁶⁾ For LVCMOS input pins with Schmitt Trigger enabled

Table 47: Maximum Toggle Rate

I/O	I/O Standard	Speed Grade	Serialization Mode	Max Toggle Rate (Mbps) ⁽¹⁷⁾⁽¹⁸⁾
HVIO	3.0 V, 3.3 V LVTTTL 3.0 V, 3.3 V LVCMOS	All	–	200
HVIO	2.5 V LVCMOS	All	–	100
HVIO	1.8 V LVCMOS	All	–	400
HSIO	1.8 V, 1.5 V, 1.2 V LVCMOS	All	–	400
HSIO	1.8 V, 1.5 V, 1.35 V, 1.2 V SSTL 1.8 V, 1.5 V, 1.2 V HSTL	All	–	800
HSIO	LVDS	C4, I3, Q3	Full-rate	1,000
			Half-rate	1,500
		C3	Full-rate	1,000
			Half-rate	1,300
		C4L, I3L	Full-rate	800
			Half-rate	1,250
		C3L	Full-rate	800
			Half-rate	1,100
HSIO	Sub-LVDS	C3, C4, I3, Q3	Full-rate	1,000
			Half-rate	1,250
		C3L, C4L, I3L	Full-rate	800
			Half-rate	1,250
HSIO	MIPI lane	C4, I3, Q3	–	1,500
		C3	–	1,300
		I3L, C4L	–	1,250
		C3L	–	1,100

Table 48: HVIO Internal Weak Pull-Up and Pull-Down Resistance

I/O Standard	Internal Pull-Up			Internal Pull-Down			Units
	Min	Typ	Max	Min	Typ	Max	
3.3 V LVTTTL/LVCMOS	25	42	67	24	29	33	kΩ
3.0 V LVTTTL/LVCMOS	25	42	67	24	29	33	kΩ
2.5 V LVCMOS	25	42	67	24	29	33	kΩ
1.8 V LVCMOS	25	35	45	24	29	33	kΩ

⁽¹⁷⁾ The maximum toggle rate is dependent on the drive strength and external load conditions. Perform IBIS simulation to determine the optimal drive strength setting to achieve the targeted toggle rate.

⁽¹⁸⁾ All I/O standards are characterized with 5 pF load, except for LVTTTL and LVCMOS standards which are characterized with 15 pF load.

Table 49: HSIO Internal Weak Pull-Up and Pull-Down Resistance

CDONE and CRESET_N also have an internal weak pull-up with these values.

I/O Standard	Speed Grade	Internal Pull-Up			Internal Pull-Down			Units
		Min	Typ	Max	Min	Typ	Max	
1.8 V LVCMOS, HSTL, SSTL	C3, C4, I3, C3L, C4L, I3L	18	27	47	18	27	47	k Ω
	Q3	15	27	47	15	27	47	k Ω
1.5 V LVCMOS, HSTL, SSTL	C3, C4, I3, C3L, C4L, I3L	22	38	65	22	38	65	k Ω
	Q3	20	38	65	20	38	65	k Ω
1.35 V SSTL	C3, C4, I3, C3L, C4L, I3L	30	52	100	30	52	100	k Ω
	Q3	22	52	100	22	52	100	k Ω
1.2 V LVCMOS, HSTL, SSTL	C3, C4, I3, C3L, C4L, I3L	40	66	135	40	66	135	k Ω
	Q3	25	66	135	25	66	135	k Ω

Table 50: Single-Ended I/O Programmable Delay Chain Step Size: Static

Speed Grade	Delay per Step			Units
	Min	Typ	Max	
C3, C4, I3, Q3	35	55	75	ps
C3L, C4L, I3L	50	68	89	ps

Table 51: Single-Ended I/O Programmable Delay Chain Step Size: Dynamic

Speed Grade	Delay per Step			Units
	Min	Typ	Max	
C3, C4, I3	12	18	24	ps
Q3	12	18	26	ps
C3L, C4L, I3L	15	22	28	ps

Table 52: Differential I/O Programmable Delay Chain Step Size: Static and Dynamic

Speed Grade	Delay per Step			Units
	Min	Typ	Max	
C3, C4, I3	12	18	24	ps
Q3	12	18	26	ps
C3L, C4L, I3L	15	22	28	ps

Table 53: Block RAM, DSP Block, Global Clock Buffer, DPA Performance

Description	Speed Grade			Units
	C3, C4, I3	Q3	C3L, C4L, I3L	
Block RAM maximum frequency.	1,000	900	800	MHz
DSP block maximum frequency.	1,000	900	800	MHz
Global clock buffer block maximum frequency.	1,000	1,000	800	MHz
DPA maximum data rate.	1,000	1,000	800	Mbps

HSIO Electrical and Timing Specifications

The HSIO pins comply with the LVDS EIA/TIA-644 electrical specifications.

HSIO as LVDS, Sub-LVDS, Bus-LVDS, RSDS, Mini LVDS, and SLVS

Table 54: HSIO Electrical Specifications when Configured as LVDS

Parameter	Description	Test Conditions	Min	Typ	Max	Unit
LVDS TX						
V _{CCIO}	LVDS transmitter voltage supply	–	1.71	1.8	1.89	V
V _{OD}	Output differential voltage	RL = 100 Ω	200	350	450	mV
Δ V _{OD}	Change in V _{OD}	–	–	–	50	mV
V _{OCM}	Output common mode voltage	–	1.125	1.2	1.375	V
Δ V _{OCM}	Change in V _{OCM}	–	–	–	50	mV
LVDS RX						
V _{ID}	Input differential voltage	–	100	–	600	mV
V _{ICM}	Input common mode voltage (f _{max} ≤ 1000 Mbps)	–	100	–	1,600	mV
	Input common mode voltage (f _{max} > 1000 Mbps)	–	700	–	1,400	mV
V _i	Input voltage valid range	–	0	–	1.89	V

Table 55: HSIO Timing Specifications when Configured as LVDS

Parameter	Description	Min	Typ	Max	Unit
t _{LVDS_CPA}	LVDS TX reference clock output phase accuracy	-5	–	+5	%
t _{LVDS_skew}	LVDS TX lane-to-lane skew	–	200	–	ps

Table 56: HSIO Electrical Specifications when Configured as Sub-LVDS

Parameter	Description	Test Conditions	Min	Typ	Max	Unit
Sub-LVDS TX						
VCCIO	Sub-LVDS transmitter voltage supply	–	1.71	1.8	1.89	V
V _{OD}	Output differential voltage	RL = 100 Ω	100	150	200	mV
ΔV _{OD}	Change in V _{OD}	–	–	–	50	mV
V _{OCM}	Output common mode voltage	–	0.8	0.9	1.0	V
ΔV _{OCM}	Change in V _{OCM}	–	–	–	50	mV
Sub-LVDS RX						
V _{ID}	Input differential voltage	–	100	–	600	mV
V _{ICM}	Input common mode voltage	–	100	–	1600	mV
V _i	Input voltage valid range	–	0	–	1.89	V

Table 57: HSIO Electrical Specifications when Configured as Bus-LVDS

Parameter	Description	Test Conditions	Min	Typ	Max	Unit
Bus-LVDS TX						
VCCIO	Voltage supply for LVDS transmitter	–	1.71	1.8	1.89	V
V _{OD}	Differential output voltage	RL = 27 Ω	200	250	300	mV
ΔV _{OD}	Static difference of V _{OD} (between 0 and 1)	–	–	–	50	mV
V _{OC}	Output common mode voltage	–	1.125	1.2	1.375	V
ΔV _{OC}	Output common mode voltage offset	–	–	–	50	mV
Bus-LVDS RX						
V _{ID}	Differential input voltage	–	100	–	600	mV
V _{IC}	Differential input common mode	–	100	–	1600	mV
V _i	Valid input voltage range	–	0	–	1.89	V

Table 58: HSIO Electrical Specifications when Configured as RSDS, Mini LVDS and SLVS

IO standard	V _{ID} (mV)		V _{ICM} (mV)		V _{OD} (mV)			V _{OCM} (mV)		
	Min	Max	Min	Max	Min	Typ	Max	Min	Typ	Max
RSDS	100	-	300	1400	100	200	600	500	1200	1400
Mini LVDS	200	600	400	1325	250	-	600	1000	1200	1400
SLVS	100	400	100	300	150	200	250	140	200	270

HSIO as High-Speed and Low-Power MIPI Lane

The MIPI transmitter and receiver lanes are compliant to the MIPI Alliance Specification for D-PHY Revision 1.1.

Table 59: HSIO DC Specifications when Configured as High-Speed MIPI TX Lane

Parameter	Description	Min	Typ	Max	Unit
VCCIO	High-speed transmitter voltage supply	1.14	1.2	1.26	V
V _{CMTX}	High-speed transmit static common-mode voltage	150	200	250	mV
ΔV _{CMTX}	V _{CMTX} mismatch when output is Differential-1 or Differential-0	–	–	5	mV
V _{OD}	High-speed transmit differential voltage	140	200	270	mV
ΔV _{OD}	V _{OD} mismatch when output is Differential-1 or Differential-0	–	–	14	mV
V _{OHHS}	High-speed output high voltage	–	–	360	mV
V _{CMRX}	Common mode voltage for high-speed receive mode	70	–	330	mV

Table 60: HSIO DC Specifications when Configured as Low-Power MIPI TX Lane

Parameter	Description	Min	Typ	Max	Unit
V _{OH}	Thevenin output high level	1.1	1.2	1.3	V
V _{OL}	Thevenin output low level	-50	–	50	mV
Z _{OLP}	Output impedance of low-power transmitter	110	–	–	Ω

Table 61: HSIO DC Specifications when Configured as High-Speed MIPI RX Lane

Parameter	Description	Min	Typ	Max	Unit
V _{CMRX(DC)}	Common mode voltage high-speed receiver mode	70	–	330	mV
V _{IDTH}	Differential input high threshold	–	–	70	mV
V _{IDTL}	Differential input low threshold	-70	–	–	mV
V _{IHHS}	Single-ended input high voltage	–	–	460	mV
V _{ILHS}	Single-ended input low voltage	-40	–	–	mV

Table 62: HSIO DC Specifications when Configured as Low-Power MIPI RX Lane

Parameter	Description	Min	Typ	Max	Unit
V _{IH}	Logic 1 input voltage	880	–	–	mV
V _{IL}	Logic 0 input voltage, not in ULP state	–	–	550	mV
V _{IL-ULPS}	Logic 0 input voltage, ULPS state	–	–	300	mV
V _{HYST}	Input hysteresis	25	–	–	mV

PLL Timing and AC Characteristics

The following tables describe the PLL timing and AC characteristics.

Table 63: PLL Timing

Symbol	Parameter	Min	Typ	Max	Units
F_{IN}	Input clock frequency.	16	–	800	MHz
F_{OUT}	Output clock frequency.	0.1342	–	1,000	MHz
F_{VCO}	PLL VCO frequency.	2,200	–	5,500	MHz
F_{PLL}	Post-divider PLL VCO frequency.	–	–	4,000	MHz
F_{PFD}	Phase frequency detector input frequency.	16	–	800	MHz

Table 64: PLL AC Characteristics⁽¹⁹⁾

Symbol	Parameter	Min	Typ	Max	Units
t_{DT}	Output clock duty cycle.	45	50	55	%
$t_{OPJIT} (PK - PK)^{(20)}$	Output clock period jitter (PK-PK).	–	–	200	ps
$t_{OPJITN} (PK - PK)^{(21)(22)}$	Output clock period jitter (PK-PK) with noisy input.	–	–	400	ps
t_{PLL_HLW}	PLL input clock HIGH/LOW pulse width	0.56	–	–	ns
t_{LOCK}	PLL lock-in time.	–	300	500	PFD ⁽²³⁾

⁽¹⁹⁾ Test conditions at nominal voltage and room temperature.

⁽²⁰⁾ The output jitter specification applies to the PLL jitter when an input jitter of 20 ps is applied.

⁽²¹⁾ The output jitter specification applies to the PLL jitter with maximum allowed input jitter of 800 ps.

⁽²²⁾ The period jitter is measured over 10,000 sample size with minimal core and I/O activity.

⁽²³⁾ PFD cycle equals to reference clock division divided by reference clock frequency.

Configuration Timing

The Ti60 FPGA has the following configuration timing specifications.



Note: Refer to AN 033: Configuring TJ-Series FPGAs for detailed configuration information.

Timing Parameters Applicable to All Modes

Table 65: All Modes

Symbol	Parameter	Min	Typ	Max	Units
$t_{\text{CRESET_N}}$	Minimum CRESET_N low pulse width required to trigger re-configuration.	0.32	–	–	μs
t_{USER}	Minimum configuration duration after CDONE goes high before entering user mode. Test condition at 10 k Ω pull-up resistance and 10 pF output loading on CDONE pin.	25	–	–	μs



Note: The FPGA may go into user mode before t_{USER} has elapsed. However, Elitestek recommends that you keep the system interface to the FPGA in reset until t_{USER} has elapsed.

For JTAG programming, the min t_{USER} configuration time is required after CDONE goes high and the FPGA receives the ENTERUSER instruction from the JTAG host (TAP controller in UPDATE_IR state).

JTAG Mode

Figure 43: JTAG Timing Waveform

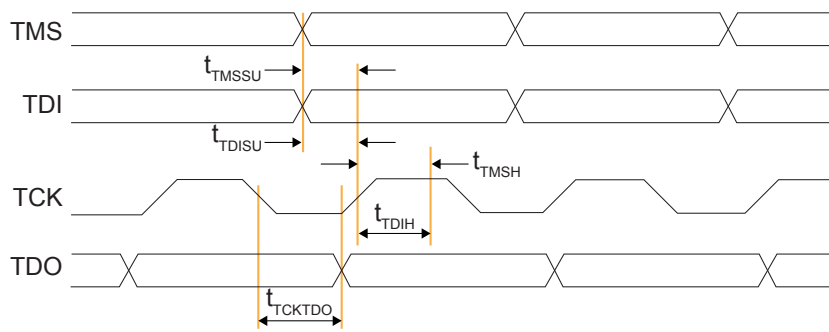

Table 66: JTAG Mode Timing

Symbol	Parameter	Min	Typ	Max	Units
f_{TCK}	TCK frequency.	–	–	10	MHz
	TCK frequency (1.8 V).	–	–	3	MHz
t_{TDISU}	TDI setup time. ⁽²⁴⁾	15	–	–	ns
t_{TDIH}	TDI hold time. ⁽²⁴⁾	2.5	–	–	ns
t_{TMSSU}	TMS setup time. ⁽²⁴⁾	15	–	–	ns
t_{TMSSH}	TMS hold time. ⁽²⁴⁾	2.5	–	–	ns
t_{TCKTDO}	TCK falling edge to TDO output. ⁽²⁴⁾	–	–	30	ns
t_{DMIN}	Minimum time between deassertion of CRESET_N to the start of JTAG configuration.	32	–	–	μ s

⁽²⁴⁾ Applicable for all voltage ranges.

SPI Active Mode

Figure 44: SPI Active (x1) Timing Sequence

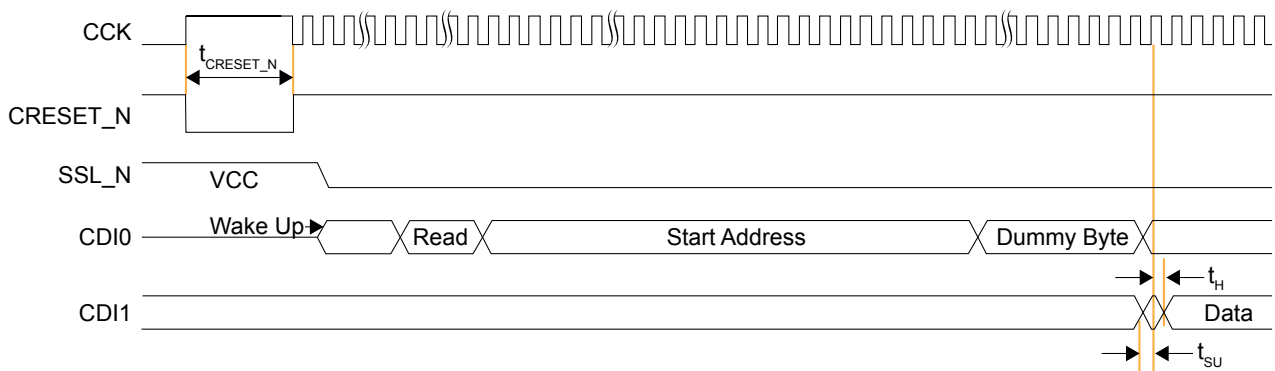

Note: The waveform shows the perspective from the control block without any optional external pull-up or pull-down resistors connected.

Table 67: Active Mode Timing

Symbol	Parameter	Frequency	Min	Typ	Max	Units
f_{MAX_M}	Active mode internal configuration clock frequency.	DIV1	52	80	100	MHz
		DIV2	26	40	52	MHz
		DIV4	13	20	26	MHz
		DIV8	6.5	10	13	MHz
$f_{MAX_M_EXTCLK}$	Active mode external configuration clock frequency.	–	–	–	100	MHz
t_{SU}	Setup time. Test condition at 1.8 V I/O standard and 0 pF output loading.	–	3	–	–	ns
t_H	Hold time. Test condition at 1.8 V I/O standard and 0 pF output loading.	–	0	–	–	ns

SPI Passive Mode

Figure 45: SPI Passive Mode (x1, Mode 3) Timing Sequence

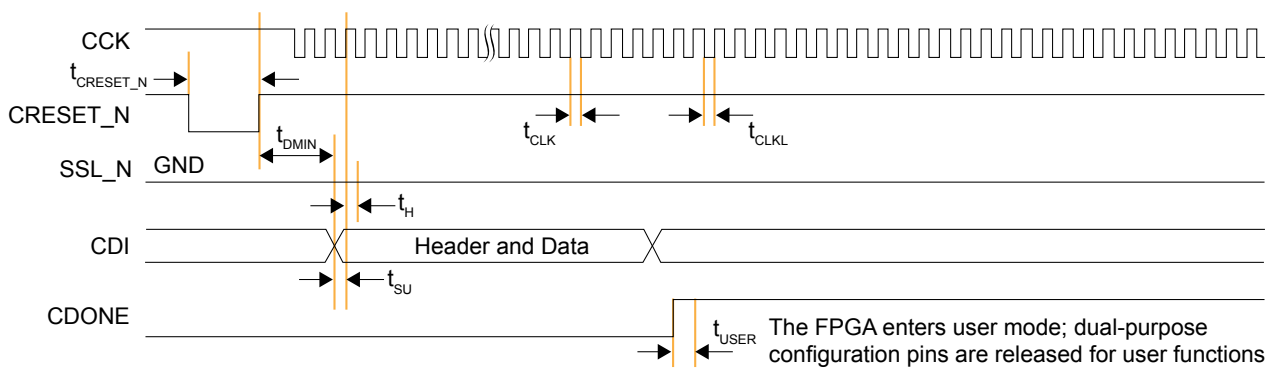

Note:

- The waveform shows the perspective from the control block without any optional external pull-up or pull-down resistors connected.
- CDI input data is clocked by CCK. To prevent configuration failure, CCK must stop toggling if the bitstream data becomes invalid. You must resume with the next bitstream data before stopping to continue the configuration.
- CSI must stay high during configuration.
- SSL_N must stay low during configuration.
- Elitestek does not recommend connecting multiple slaves on the same SPI bus.



Important: To ensure successful configuration, the microprocessor must continue to supply the configuration clock to the TJ-Series FPGA for at least 100 cycles after sending the last configuration data.

Table 68: Passive Mode Timing

Symbol	Parameter	Min	Typ	Max	Units
$f_{\text{MAX_S}}$	Passive mode configuration clock frequency.	–	–	100	MHz
t_{CLKH}	Configuration clock pulse width high.	4.8	–	–	ns
t_{CLKL}	Configuration clock pulse width low.	4.8	–	–	ns
t_{SU}	Setup time.	2	–	–	ns
t_{H}	Hold time.	1	–	–	ns
t_{DMIN}	Minimum time between deassertion of CRESET_N to first valid configuration data.	32	–	–	μs

Pinout Description

The following tables describe the pinouts for power, ground, configuration, and interfaces.

Table 69: Power and Ground Pinouts

xx indicates the bank location.

Function	Description
VCC	Core power supply.
VCCA_xx	PLL analog power supply.
VCCAUX	1.8 V auxiliary power supply.
VCCIO33_xx	HVIO bank power supply.
VCCIOxx	HSIO bank power supply.
VCCIOxx_yy_zz	Power for HSIO banks that are shorted together. xx, yy, and zz are the bank locations. For example: VCCIO1B_1C shorts banks 1B and 1C
VQPS	1.8 V supply for security fuse.
GND	Ground.

Table 70: GPIO Pinouts

x indicates the location (T, B, L, or R); xx indicates the bank location; n indicates the number; yyyy indicates the function.

Function	Direction	Description
GPIOx_n	I/O	HVIO for user function. User I/O pins are single-ended.
GPIOx_n_yyyy	I/O	HVIO or multi-function pin.
GPIOx_N_n GPIOx_P_n	I/O	HSIO transmitter, receiver, or both.
GPIOx_N_n_yyyy GPIOx_P_n_yyyy	I/O	HSIO transmitter, receiver, both, or multi-function.
REF_RES_xx	–	<p>REF_RES is a reference resistor to generate constant current for the related circuits.</p> <p>Connect the following REF_RES pins to ground through a 10 kΩ resistor with a tolerance of $\pm 1\%$:</p> <ul style="list-style-type: none"> REF_RES_2A and REF_RES_4A pins must be connected. REF_RES pin of the particular bank, if pins in the bank are used as LVDS TX or MIPI TX lane. REF_RES_3A pin, if internal oscillator is used. REF_RES_3A pin, if blowing of fuses for FPGA security is required. <p>You can leave the REF_RES pins floating if none of the above are applicable.</p>

Table 71: Alternate Function Pinouts

n is the number.

Function	Direction	Description
CLKn	Input	Single ended input for global clock and control network resource. The number of inputs is package dependent.
EXTFB	Input	PLL external feedback CLKIN.

Function	Direction	Description
PLLINn	Input	PLL reference clock resource. The number of reference clock resources is package dependent.

Configuration Pins

Table 72: Dedicated Configuration Pins

These pins cannot be used as general-purpose I/O after configuration.

All the pins are in internal weak pull-up during configuration mode except for TCK and TDO.

Calculate the resistor value as described in "Resistors in Configuration Circuitry" in AN 033: Configuring TJ-Series FPGAs.

Pins	Direction	Description	External Weak Pull Up/ Pull Down Requirement
CDONE	I/O	Configuration done status pin. CDONE is an open drain output; connect it to an external pull-up resistor to VCCIO. When CDONE = 1, the configuration is complete and the FPGA enters user mode. You can hold CDONE low and release it to synchronize the FPGAs entering user mode.	Pull up
CRESET_N	Input	Active-low FPGA reset and re-configuration trigger. Pulse CRESET_N low for a duration of $t_{\text{creset_N}}$ before releasing CRESET_N from low to high to initiate FPGA re-configuration. This pin does not perform a system reset.	Pull up
TCK	Input	JTAG test clock input (TCK). The rising edge loads signals applied at the TAP input pins (TMS and TDI). The falling edge clocks out signals through the TAP TDO pin.	Pull up
TMS	Input	JTAG test mode select input (TMS). The I/O sequence on this input controls the test logic operation. The signal value typically changes on the falling edge of TCK. TMS is typically a weak pull-up; when it is not driven by an external source, the test logic perceives a logic 1.	Pull up
TDI	Input	JTAG test data input (TDI). Data applied at this serial input is fed into the instruction register or into a test data register depending on the sequence previously applied at TMS. Typically, the signal applied at TDI changes state following the falling edge of TCK while the registers shift in the value received on the rising edge. Like TMS, TDI is typically a weak pull-up; when it is not driven from an external source, the test logic perceives a logic 1.	Pull up
TDO	Output	JTAG test data output (TDO). This serial output from the test logic is fed from the instruction register or a test data register depending on the sequence previously applied at TMS. The shift out content is based on the issued instruction. The signal driven through TDO changes state following the falling edge of TCK. When data is not being shifted through the device, TDO is set to an inactive drive state (e.g., high-impedance).	Pull up

⁽²⁵⁾ CDONE has a drive strength of 12 mA at 1.8 V.

Table 73: Dual-Purpose Configuration Pins

In user mode (after configuration), you can use these dual-purpose pins as general I/O.

Calculate the resistor value as described in "Resistors in Configuration Circuitry" in AN 033: Configuring TJ-Series FPGAs.

Pins	Direction	Description	External Weak Pull Up/Pull Down Requirement
CBSEL[1:0]	Input	Multi-image configuration selection pin. This function is not applicable to single-image bitstream configuration or internal reconfiguration (remote update). Connect CBSEL[1:0] to the external resistors for the image you want to use: 00 for image 1 01 for image 2 10 for image 3 11 for image 4 0: Connect to an external weak pull down. 1: Connect to an external weak pull up.	Pull up or pull down
CCK	I/O	Passive SPI input configuration clock or active SPI output configuration clock.	Optional pull up if required by external load
CDIn	I/O	Data input for SPI configuration. n is a number from 0 to 31 depending on the SPI configuration data width. CDI0 is an output in x1 active configuration mode and is a bidirectional pin in all other active configuration modes. CDI4 is a bidirectional pin in x8 active configuration mode. In a multi-bit daisy chain connection, CDIn[31:0] connects to the data bus in parallel.	Optional pull up if required by external load
CSI	Input	Chip select. 0: The FPGA is not selected or enabled and will not be configured. 1: Select the FPGA for all configuration modes. This pin is not bonded out in some of the smaller packages, such as the F100.	Pull up
CSO	Output	Chip select output. Asserted after configuration is complete. Connect this pin to the chip select pin of the next FPGA for daisy chain configuration. This pin is not bonded out in some of the smaller packages, such as the F100.	–
NSTATUS	Output	Indicates a configuration error. When the FPGA drives this pin low, it indicates an ID mismatch, the bitstream CRC check has failed, or remote update has failed.	–
SSL_N	I/O	SPI configuration mode select. The FPGA senses the value of SSL_N when it comes out of reset (i.e., CRESET_N transitions from low to high). 0: Passive mode; connect to external weak pull down. 1: Active mode; connect to external weak pull up. In active configuration mode, SSL_N is an active-low chip select to the flash device (CDI0 - CDI3).	Pull up or pull down
SSU_N	Output	Active-low chip select to the upper flash device (CDI4 - CDI17) in active x8 configuration mode (dual quad mode). Not available on W64 and F100 packages.	Optional pull up if required by external load
EXT_CONFIG_CLK	Input	Alternative clock in active configuration mode.	Optional pull up if required by external load
TEST_N	Input	Active-low test mode enable signal. Set to 1 to disable test mode. During all configuration modes, rely on the external weak pull-up or drive this pin high.	Pull up

Ti60 Interface Floorplan



Note: The numbers in the floorplan figures indicate the HVIO and HSIO number ranges. Some packages may not have all HVIO or HSIO pins in the range bonded out. Refer to the Ti60 Pinout for information on which pins are available in each package.

Figure 46: Floorplan Diagram for W64 Packages

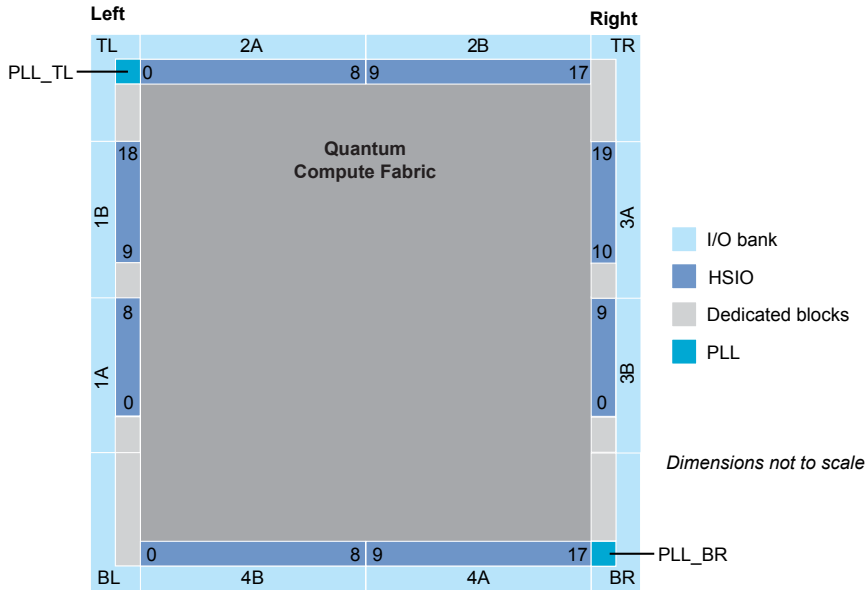

Figure 47: Floorplan Diagram for F100 and F100S3F2 Packages

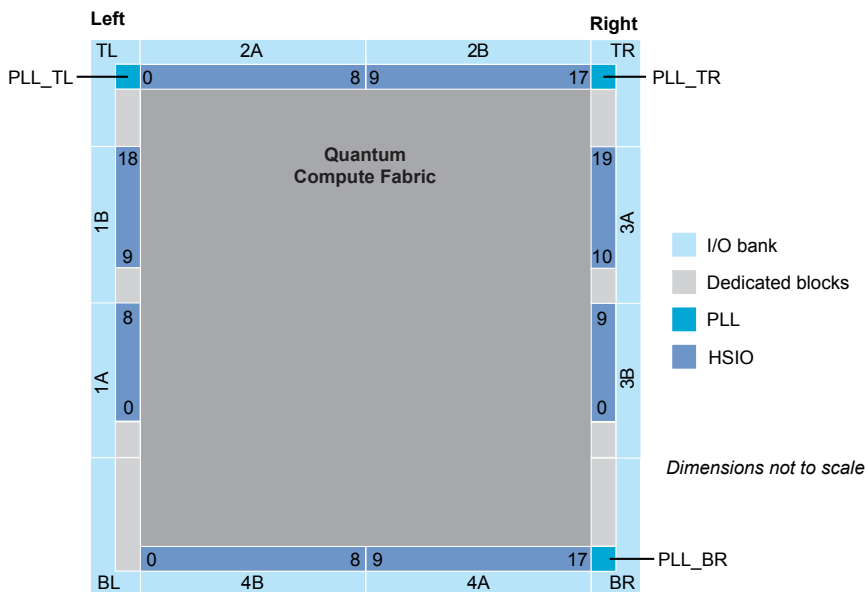
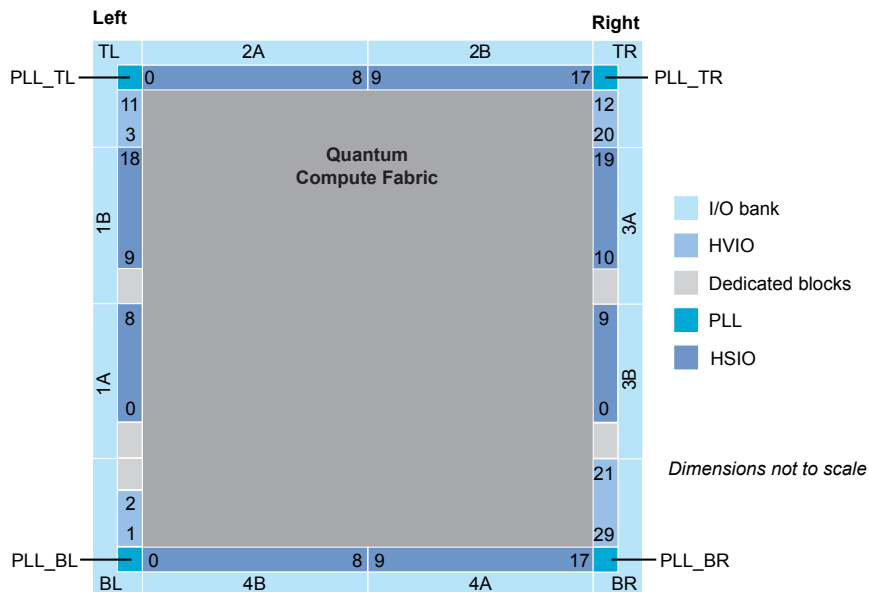

Figure 48: Floorplan Diagram for F225 and F256 Packages



Efinity Software Support

The Efinity[®] software provides a complete tool flow from RTL design to bitstream generation, including synthesis, place-and-route, and timing analysis. The software has a graphical user interface (GUI) that provides a visual way to set up projects, run the tool flow, and view results. The software also has a command-line flow and Tcl command console. The Efinity[®] software supports simulation flows using the ModelSim, NCSim, or free iVerilog simulators. An integrated hardware Debugger with Logic Analyzer and Virtual I/O debug cores helps you probe signals in your design. The software-generated bitstream file configures the Ti60 FPGA. The software supports the Verilog HDL and VHDL languages.

Ordering Codes

Refer to the TJ-Series Selector Guide for the full listing of Ti60 ordering codes.

Revision History

Table 74: Revision History

Date	Version	Description
May 2024	3.2	Security features are updated for W64, F100S3F2, and F225 packages. (DOC-1867)
March 2024	3.1	<p>Added Q3 specifications.</p> <p>Added F100 and F256 packages. (DOC-1594)</p> <p>Added EXTFB to table of alternate pin functions.</p> <p>Corrected OUTCLK connection in Page26 Figure 20: I/O Interface Block. (DOC-1630)</p> <p>Rearranged Page64 Configuration Timing to keep waveforms together with tables.</p> <p>For the PLL equation $F_{VCO} = (F_{PFD} \times M \times O \times C_{FBK})$, removed the restriction that $(M \times O \times C_{FBK})$ must be ≤ 255.</p> <p>Updated Page70 Configuration Pins.</p> <p>Added 1.35 V support.</p> <p>Updated oscillator specification. (DOC-1663)</p> <p>Updated description for HSIO block DLY_INC signal. (DOC-1697)</p> <p>F100S3F2 supports SPI active x4 mode. (DOC-1707)</p>
November 2023	3.0	<p>Removed table Single-Ended I/O and Dedicated Configuration Pins Schmitt Trigger Buffer Characteristic. Added 3.3 V and 2.5 V in table HSIO Pins Configured as Single-Ended I/O DC Electrical Characteristics. Added table Supported HVIO Drive Strength and Supported HSIO Drive Strength. (DOC-1377)</p> <p>Updated min ramp time in table Power Supply Ramp Rates. (DOC-1407)</p> <p>Updated CRESET_N requirement during power-up sequence. (DOC-1443)</p> <p>Corrected typo for VCCIO33 max supply in Absolute Maximum Ratings table. (DOC-1483)</p> <p>Added max. value of f_{TCK} at 3 MHz at an operating voltage of 1.8 V to in JTAG Mode table. Added max.value of V_{IL} at 0.28 V for 1.8 V JTAG Configuration in HVIO DC Electrical Characteristics. (DOC-1510 & ADV-2311-001)</p> <p>Corrected typo in HSIO Pins Configured as Differential SSTL I/O Electrical Characteristics table. (DOC-1514)</p> <p>Updated power-up sequence.</p> <p>Updated initial CCK waveform of figure SPI Passive Mode (x1) Timing Sequence.</p>
August 2023	2.9	<p>Updated Programmable Delay Chains section, and added static and dynamic delay step size specs. (DOC-1342)</p> <p>Added note about keeping both the current and the next clocks toggling during dynamic clock switching. (DOC-1405)</p>
June 2023	2.8	<p>Added note about 7 x 6 Quad mode output is truncated to 12-bit (DOC-1295)</p> <p>Added slvs option for HSIO configured as LVDS blocks. (DOC-1190)</p> <p>Updated SPI Flash Memory port list. (DOC-1296)</p>
May 2023	2.7	<p>Improved MIPI RX function description and added missing MIPI RX signal descriptions. (DOC-1173)</p> <p>Updated 2.5 V LVCMOS max toggle rate. (DOC-1251)</p> <p>Replaced t_{LVDS_DT} and t_{INDT} specs with t_{PLL_HLW} and t_{LVDS_CPA}. (DOC-1189)</p> <p>Updated PLL LOCKED signal description. (DOC-1208)</p>
April 2023	2.6	<p>Added LVDS RX DBG signals. (DOC-1124)</p> <p>Added note about using LVDS blocks from the same side of the FPGA to minimize skew. (DOC-1150)</p> <p>Updated PLL RSTN signal description about de-asserting only when CLKIN is stable. (DOC-1226)</p>

Date	Version	Description
February 2023	2.5	Standardized VCCA pin names. (DOC_1114) Added note about achieving maximum toggle rate. (DOC-1099) Added link in Power Up Sequence pointing to the Web Interactive Hardware Design Checklist and Guidelines. (DOC-1123) Updated REF_RES_3A pin connection requirement in the Pinout Description topic.
December 2022	2.4	Updated configuration pins external weak pull-up requirements. (DOC-1035) Added DPA specs and updated DPA description to support full-rate serialization mode only. (DOC-1078) Updated LVDS and sub-LVDS specs to include half-rate and full-rate serialization. (DOC-1078) Updated JTAG configuration timing specs. (DOC-1083)
October 2022	2.3	Updated REF_RES_xx pins connection requirement. (DOC-943)
September 2022	2.2	Updated t_{RESET_N} spec. (DOC-876) Corrected MIPI RX Lane Block Diagram. (DOC-878) Removed GCTRL and RCTRL. (DOC-895) Added note recommending up to only 2 cascading PLLs. (DOC-931) Updated description about differential receivers are powered by VCCAUX. (DOC-929)
July 2022	2.1	Updated note about pins separation when using HSIO as GPIO, LVDS, or MIPI lanes. (DOC-769) Removed footnote in Minimum Power Supply Current Transient table. (DOC-818) Corrected SSU_N pin direction. Added note about I/O availability when enabling SPI flash memory access during user mode for F100S3F2 packages. (DOC-824) Updated I/O Banks by Package table. Corrected available single-ended HSIO for W64 package.
April 2022	2.0	Updated test condition load to maximum load in Maximum Toggle Rate Table. (DOC-781) Corrected description for differential TX static programmable delay. (DOC-786) Added notes about VCC requirements in SPI flash memory and HyperRAM for F100S3F2 packages. (DOC-773) Added PLL period jitter spec with noisy input clock specs and updated test condition note. (DOC-771) Updated HyperRAM clock rate and double data rate speed. (DOC-793)
April 2022	1.9	Updated figure title for Connections for Clock and RX Data Lane in the Same MIPI RX Group. (DOC-739) Updated LVDS/RSDS/mini-LVDS RX supported VCCIO. (DOC-740) Updated Power Supply Current Transient and power sequence. (DOC-761) Corrected RD and RST signal directions in MIPI RX Lane Block Diagram.
March 2022	1.8	Updated power supply ramp rate and power up sequence diagram. (DOC-631) Updated external pull-up requirement for dual-purpose configuration pins. (DOC-734)
February 2022	1.7	Corrected t_{H} and t_{SU} parameter label in SPI Passive Mode (x1) Timing Sequence figure. Updated active and passive configuration timing specs. (DOC-708) Update 2.5 V LVCMOS V_{IH} and V_{IL} specs. (DOC-718) Added I_{IN} and V_{IN} specs. (DOC-652) Updated and improved clock and control network content and figures. (DOC-668) Updated MIPI and LVDS maximum toggle rate. Added note about the block RAM content is random and undefined if it is not initialized. (DOC-729)
January 2022	1.6	Corrected Available Package Options.
January 2022	1.5	Merged MIPI and LVDS data rate specs into Maximum Toggle Rate table.

Date	Version	Description
January 2022	1.4	I/O banks for HVIO pins support dynamic voltage shifting. (DOC-444) Added Schmitt Trigger input buffer specs. (DOC-606) Added PLL reference clock input duty cycle specs. (DOC-661) Updated HVIO maximum toggle rate specs. (DOC-689) Removed I4 and I4L speed grades. (DOC-681) Updated global clock buffer, DSP, BRAM, HSIO as LVDS, and HSIO as MIPI lane specs. (DOC-693) Added internal weak pull-up resistor and drive strength specs for CDONE and CRESET_N. (DOC-635) Added ambient storage temperature spec. (DOC-678)
November 2021	1.3	Updated REF_RES_xx description and resistor tolerance. (DOC-602, DOC-603, DOC-605) Added Ordering Codes topic. (DOC-637) Added SRL8 resource number. (DOC-596) Added global clock buffer block characteristics. (DOC-577) Updated power up sequence, updated power supply ramp rates, updated t_{CRESET_N} and added power supply current transient specs. (DOC-643)
November 2021	1.2	Added internal weak pull-up and pull-down specs for HVIO and HSIO. (DOC-561) Updated the SHIFT[2:0] description in PLL Signals table and Dynamic Phase Shift topic. (DOC-570) Updated note about leaving unassigned pins when using HSIO as GPIO, LVDS, or MIPI lanes. (DOC-581) Updated the Security Feature topic. (DOC-538) Added a note in the Ti-series Single Event Upset Detection topic referring to the Ti-series Interfaces User Guide for details on using this feature. Updated LVDS standard compliance which is TIA/EIA-644. (DOC-592) Updated F100 package name to F100S3F2. (DOC-593)
October 2021	1.1	Updated the Security Feature topic. Updated DIV 2 active mode f_{MAX_M} typical and maximum values. (DOC-509) Added F_{PLL} specs and updated the PLL block diagram to include F_{PLL} . (DOC-512) Added note stating that all PLL outputs lock on the negative clock edge. (DOC-511) Updated sub-LVDS maximum toggle rate. (DOC-541) Added description about CLKOUT0 limitation. (DOC-533) Updated HyperRAM double-data rates to up to 500 Mbps. (DOC-554) Added connection requirements for unused resources in Power Up Sequence topic.
June 2021	1.0	Initial release.